



Swing Barrier
Quick Start Guide

Legal Information

© 2020 Hangzhou Hikvision Digital Technology Co., Ltd. All rights reserved.

This Manual is the property of Hangzhou Hikvision Digital Technology Co., Ltd. or its affiliates (hereinafter referred to as "Hikvision"), and it cannot be reproduced, changed, translated, or distributed, partially or wholly, by any means, without the prior written permission of Hikvision. Unless otherwise expressly stated herein, Hikvision does not make any warranties, guarantees or representations, express or implied, regarding to the Manual, any information contained herein.

About this Manual

The Manual includes instructions for using and managing the Product. Pictures, charts, images and all other information hereinafter are for description and explanation only. The information contained in the Manual is subject to change, without notice, due to firmware updates or other reasons. Please find the latest version of this Manual at the Hikvision website (<https://www.hikvision.com/>).

Please use this Manual with the guidance and assistance of professionals trained in supporting the Product.

Trademarks Acknowledgement

- **HIKVISION** and other Hikvision's trademarks and logos are the properties of Hikvision in various jurisdictions.
- Other trademarks and logos mentioned are the properties of their respective owners.

LEGAL DISCLAIMER

TO THE MAXIMUM EXTENT PERMITTED BY APPLICABLE LAW, THIS MANUAL AND THE PRODUCT DESCRIBED, WITH ITS HARDWARE, SOFTWARE AND FIRMWARE, ARE PROVIDED "AS IS" AND "WITH ALL FAULTS AND ERRORS". HIKVISION MAKES NO WARRANTIES, EXPRESS OR IMPLIED, INCLUDING WITHOUT LIMITATION, MERCHANTABILITY, SATISFACTORY QUALITY, OR FITNESS FOR A PARTICULAR PURPOSE. THE USE OF THE PRODUCT BY YOU IS AT YOUR OWN RISK. IN NO EVENT WILL HIKVISION BE LIABLE TO YOU FOR ANY SPECIAL, CONSEQUENTIAL, INCIDENTAL, OR INDIRECT DAMAGES, INCLUDING, AMONG OTHERS, DAMAGES FOR LOSS OF BUSINESS PROFITS, BUSINESS INTERRUPTION, OR LOSS OF DATA, CORRUPTION OF SYSTEMS, OR LOSS OF DOCUMENTATION, WHETHER BASED ON BREACH OF CONTRACT, TORT (INCLUDING NEGLIGENCE), PRODUCT LIABILITY, OR OTHERWISE, IN CONNECTION WITH THE USE OF THE PRODUCT, EVEN IF HIKVISION HAS BEEN ADVISED OF THE POSSIBILITY OF SUCH DAMAGES OR LOSS.

YOU ACKNOWLEDGE THAT THE NATURE OF INTERNET PROVIDES FOR INHERENT SECURITY RISKS, AND HIKVISION SHALL NOT TAKE ANY RESPONSIBILITIES FOR ABNORMAL OPERATION, PRIVACY LEAKAGE OR OTHER DAMAGES RESULTING FROM CYBER-ATTACK, HACKER ATTACK, VIRUS INSPECTION, OR OTHER INTERNET SECURITY RISKS; HOWEVER, HIKVISION WILL PROVIDE TIMELY TECHNICAL SUPPORT IF REQUIRED.

YOU AGREE TO USE THIS PRODUCT IN COMPLIANCE WITH ALL APPLICABLE LAWS, AND YOU ARE SOLELY RESPONSIBLE FOR ENSURING THAT YOUR USE CONFORMS TO THE APPLICABLE LAW. ESPECIALLY, YOU ARE RESPONSIBLE, FOR USING THIS PRODUCT IN A MANNER THAT DOES NOT INFRINGE ON THE RIGHTS OF THIRD PARTIES, INCLUDING WITHOUT LIMITATION, RIGHTS OF PUBLICITY, INTELLECTUAL PROPERTY RIGHTS, OR DATA PROTECTION AND OTHER PRIVACY RIGHTS. YOU SHALL NOT USE THIS PRODUCT FOR ANY PROHIBITED END-USES, INCLUDING THE DEVELOPMENT OR PRODUCTION OF WEAPONS OF MASS DESTRUCTION, THE DEVELOPMENT OR PRODUCTION OF CHEMICAL OR BIOLOGICAL WEAPONS, ANY ACTIVITIES IN THE CONTEXT RELATED TO ANY NUCLEAR EXPLOSIVE OR .

Data Protection

During the use of device, personal data will be collected, stored and processed. To protect data, the development of Hikvision devices incorporates privacy by design principles. For example, for device with facial recognition features, biometrics data is stored in your device with encryption method; for fingerprint device, only fingerprint template will be saved, which is impossible to reconstruct a fingerprint image.

As data controller, you are advised to collect, store, process and transfer data in accordance with the applicable data protection laws and regulations, including without limitation, conducting security controls to safeguard personal data, such as, implementing reasonable administrative and physical security controls, conduct periodic reviews and assessments of the effectiveness of your security controls.

FCC Information

Please take attention that changes or modification not expressly approved by the party responsible for compliance could void the user's authority to operate the equipment.

FCC compliance: This equipment has been tested and found to comply with the limits for a Class A digital device, pursuant to part 15 of the FCC Rules. These limits are designed to provide reasonable protection against harmful interference when the equipment is operated in a commercial environment. This equipment generates, uses, and can radiate radio frequency energy and, if not installed and used in accordance with the instruction manual, may cause harmful interference to radio communications. Operation of this equipment in a residential area is likely to cause harmful interference in which case the user will be required to correct the interference at his own expense.

FCC Conditions

This device complies with part 15 of the FCC Rules. Operation is subject to the following two conditions:

1. This device may not cause harmful interference.
2. This device must accept any interference received, including interference that may cause undesired operation.

EU Conformity Statement



This product and - if applicable - the supplied accessories too are marked with "CE" and comply therefore with the applicable harmonized European standards listed under the EMC Directive 2014/30/EU, the LVD Directive 2014/35/EU, the RoHS Directive 2011/65/EU.



2012/19/EU (WEEE directive): Products marked with this symbol cannot be disposed of as unsorted municipal waste in the European Union. For proper recycling, return this product to your local supplier upon the purchase of equivalent new equipment, or dispose of it at designated collection points. For more

information see: www.recyclethis.info



2006/66/EC (battery directive): This product contains a battery that cannot be disposed of as unsorted municipal waste in the European Union. See the product documentation for specific battery information.

The battery is marked with this symbol, which may include lettering to indicate cadmium (Cd), lead (Pb), or mercury (Hg). For proper recycling, return the battery to your supplier or to a designated collection point. For more information see: www.recyclethis.info

Industry Canada ICES-003 Compliance

This device meets the CAN ICES-3 (A)/NMB-3(A) standards requirements.



Applicable Models

This manual is applicable to the models listed in the following table.

Series	Model
DS-K3BC411X	DS-K3BC411X-L
	DS-K3BC411X-R

Symbol Conventions

The symbols that may be found in this document are defined as follows.

Symbol	Description
 Note	Provides additional information to emphasize or supplement important points of the main text.
 Caution	Indicates a potentially hazardous situation, which if not avoided, could result in equipment damage, data loss, performance degradation, or unexpected results.
 Danger	Indicates a hazard with a high level of risk, which if not avoided, will result in death or serious injury.

Safety Instructions

- Proper configuration of all passwords and other security settings is the responsibility of the installer and/or end-user.
- In the use of the product, you must be in strict compliance with the electrical safety regulations of the nation and region. Please refer to technical specifications for detailed information.
- Input voltage should meet both the SELV (Safety Extra Low Voltage) and the Limited Power Source with 100 to 240 VAC or 12 VDC according to the IEC60950-1 standard. Please refer to technical specifications for detailed information.
- Do not connect several devices to one power adapter as adapter overload may cause over-heating or a fire hazard.
- Please make sure that the plug is firmly connected to the power socket.
- If smoke, odor or noise rise from the device, turn off the power at once and unplug the power cable, and then please contact the service center.

CONTENTS

1 Product introduction	6
1.1 Brief introduction	6
1.2 Product structure and principle.....	6
1.3 Function Features	9
1.4 Technical parameters.....	9
2 Equipment Installation.....	9
2.1 Installation notes	9
2.2 Equipment Installation.....	9
2.3 Connection.....	12
2.4 Debugging instruction	12
2.5 Use notes	13
3 Control Board and parameter instruction	13
3.1 Control Board instruction	13
3.2 Wiring diagram	16
3.3 parameter instruction.....	18
4 Trouble shooting and maintenance.....	20
4.1 Trouble shooting.....	21
4.2 maintenance	22

1 Product introduction

1.1 Brief introduction

The flap /slide barrier and swing gate is a kind of 2-way speed access control equipment designed for places with high class security requirements. It is easy to combine IC access control, ID access control, code reader, fingerprint, face recognition and other identification devices, It realizes the intelligent and efficient management of passage.

1.2 Product structure and principle

The structure of the product is mainly composed of mechanical system and electric control system.

The mechanical system is composed of cabinet and core mechanism. The cabinet is equipped with indicator, infrared sensor and other device.

The core mechanism is composed of motor, position sensor, transmission, shaft.

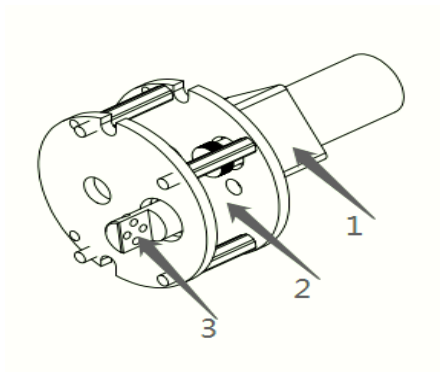

1. Motor
2. Core
3. Roting shaft

Swing core

The electric control system consists of access control system, control board, infrared sensor, direction indicator, position sensor, motor, power supply, battery and so on.

NO	Name	Function
1	Access control device	IC/ID card access control, fingerprint, face recognition, code reader, access control device send delay signal to the turnstile board door signal. Remote control or button to open the door(select the configuration)
2	Main board (control)	The control center of the system, when receiving the access control device delay signal, it control motor running so that the gate opened, the direction indicator light turns green, while receiving core position sensor, infrared sensor, and judging and processing logic of these signals, keep the gate components of intelligent coordination work
3	Infrared sensor	Detect the passage of people in the lane, Anti pinch
4	Indicator	Display the current channel status
5	Position sensor	Detects and controls the opening and closing position of the gate
6	Motor	Drive the barrier moving
7	Power Supply	power supply to control board
8	12V battery	The gate will keep open the door automatically when power failure

System Operation Principle

- 1) Turn on the power, wait for the end of the self-examination ; the system enters into work mode;
- 2) After swipe legal card or QR code and fingerprint, Access control device send opening signal to main board.
- 3) The main board receives open signal, control indicator to green, motor acts to open the barrier.
- 4) After the passenger passing through the passage in accordance with the direction indicator

mark, the infrared sensor detects the complete process of the passenger passing through the passage, and issues signal continuously to the main controller board, until the passenger passes through the passage completely.

5) After the passenger passes through the passage completely, the main controller board delivers a signal to the counter, which will increase 1 automatically, ending the passing process.

6) If the passenger forgets to swipe card when go into the passage, sound/light alarm signal will be given from main board. The alarm signal will not be cancelled until the passenger retreats from the passage and the passing is only allowed after reading again the effective card

1.3 Function Features

- Varied pass mode can be chosen flexibly;
- Standard signal input port, can be connected with most of the access control board, fingerprint device and scanner other equipment;
- The turnstile has automatic reset function, if people swipe the authorized card, but don't pass through within the settled time, it need to swipe card again for entry;
- Card-reading Recording function: single-directional or bi-directional access can be set by the users
- Automatic opening after emergency fire signal input
- Pinch protection;
- Anti-tailgating control technology
- Automatic detection, diagnosis and alarm, sound and light alarm, including trespassing alarm, anti-pinch alarm and anti-tailgating alarm.
- High light LED indicator , displaying passing status.
- Self diagnostic and alarm function for convenient maintenance and use
- Gate will automatically open when power failure(connect 12V battery)

1.4 Technical parameter

Housing Material	304 stainless steel
Power	AC220±10% V、50HZ
Working voltage	DC 24V
Motor	Brush DC motor 30W
Working temperature	-20 °C - 60 °C
Work environment	≅ 90%, no condensation
Open signal	Passive signals (relay signals, dry contact signals,)
Communication	RS485
Pass rate	≅ 35 person/min
Passage width	Swing gate 600--900mm

2 Equipment Installations

2.1 Installation notes

- Please read this manual carefully before install it;
- The gates must be correctly arranged in order, and the left and right gates of each lane should be aligned;
- If the equipment is used outdoors, equipment should be installed at the establishment of 100-200mm high cement platform, so as to prevent moisture, and install ceilings and other sunscreen, rain protection facilities;
- Protective earth wire must be connected;
- Please confirm each RJ45 cable straight through;
- Please check all wires has been properly connected before power on;
- Please test all function before using.

2.2 Equipment Installation

1) Tool preparations

1	A set of hexagon spanner	5	Screw driver and other common wiring tool
2	Cross screwdriver 6mm	6	Millimeter
3	Open spanner 17-19mm	7	M12x100 Expansion screws 8pcs
4	Impact drill(including D16 and D14 drills)	8	Cable Tester

2) Ensure the installation location and the system composition ,prepare to install after carrying out the system planning;

3) Make well of installation of equipment foundation base.

4) Mark the fixing position of expansion bolts according to fixing plate on the bottom of each turnstile.

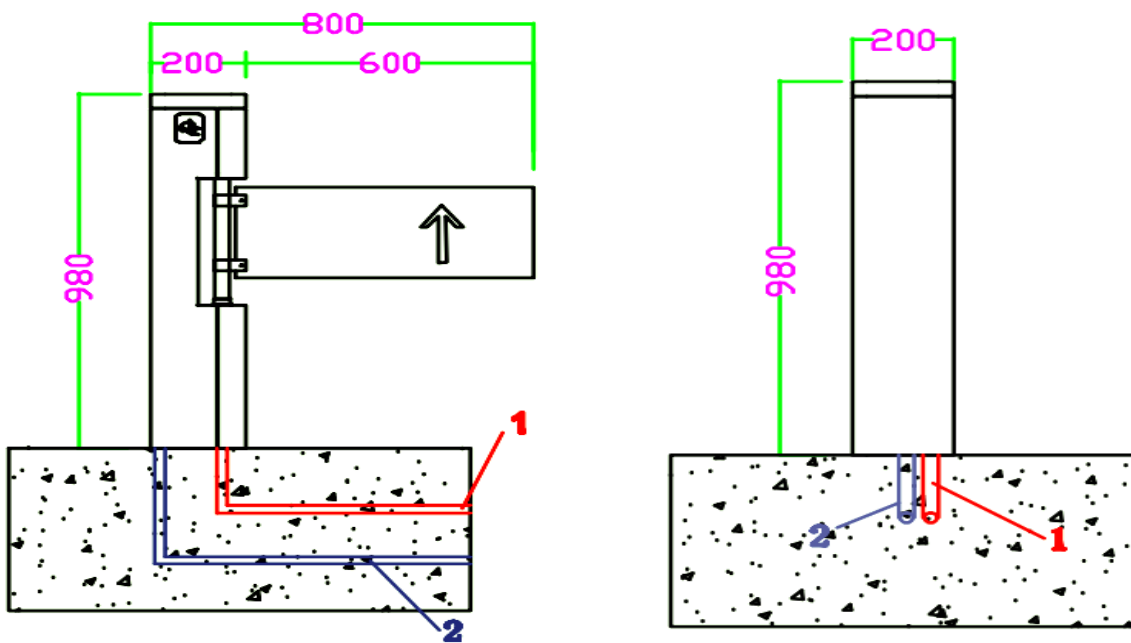

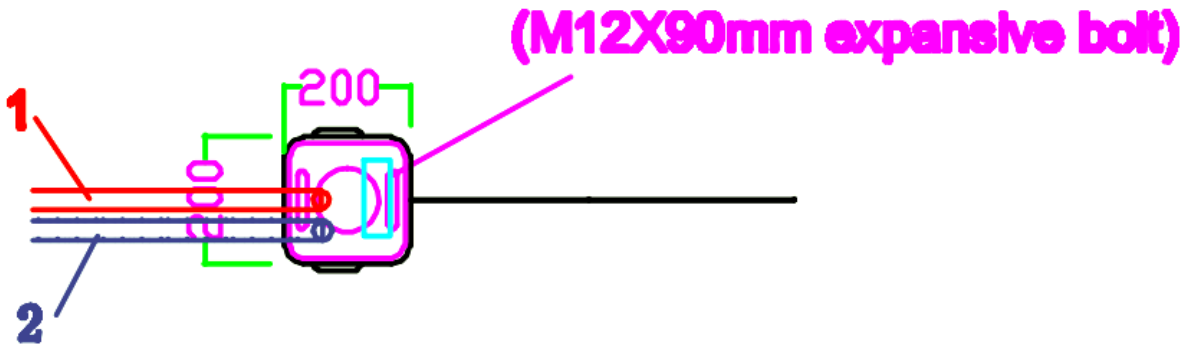

- 5) Move turnstile and drill hole by impact drill, fix Expansion screws
- 6) Tighten the expansion screw after the functional test is completed

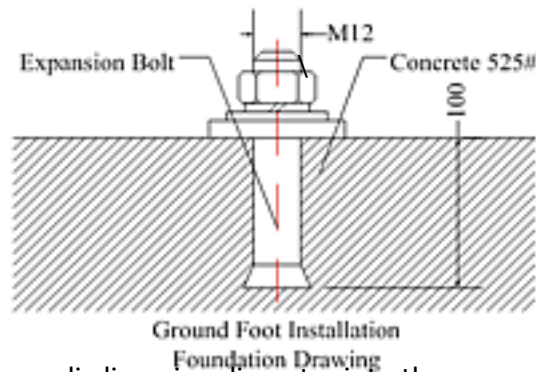

7) Confirm the lane lines, dig line pipe diameter into the appropriate PVC line pipe, each lane will AC220V power line RVV3*1.5mm and 3pcs CAT 5 cable for connect main machine , 1 PCS network cable for access control system (if install other control system according to the actual situation of laying related field the wire)

- 8) Move each machine to the corresponding mounting position and point to the expansion bolt position;
- 9) Check again;
- 10) Check each gate alignment, all lane are completed debugging and function test, then tighten the nut.

2.3 Connection

- 1) Connecting AC220V power input

Connect the mater machie power adapter to 220V and connect the protective ground wire.

2) Access control device connect

Access control device send open signal to control board , gate will open immediately ,The relay time of access control device must be set to 0-1 seconds.

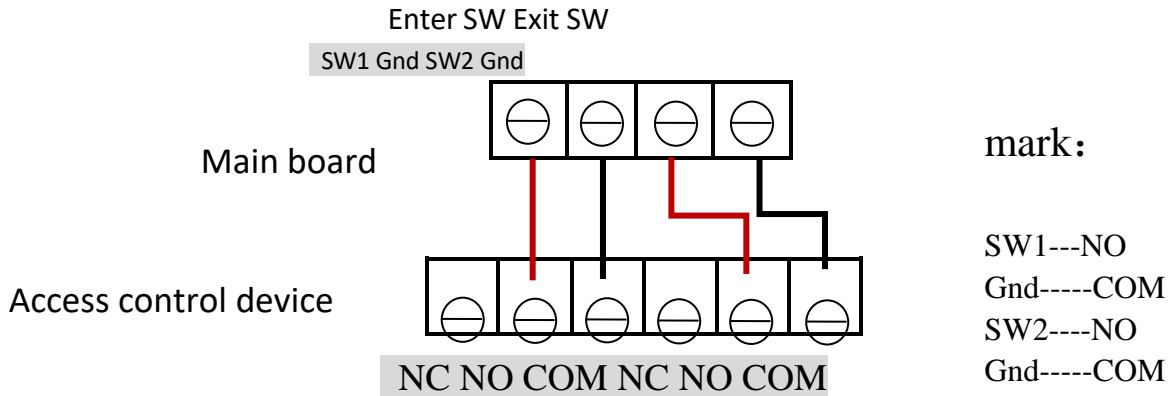

2.4 Debugging instruction

1) Check wire: Check whether the connection wire of the gate and the power line are properly connected before power on. If there is any abnormality on the power supply process, check the connection wires firstly;

2) Function test: After power on the machine will open- close, and open -close, this process is machine self-check, after the sound from buzzer means finish self-check. Don't stand in the lane in the process of self-check;

3) The control board will give alarm if stand in the lane without swipe card ;if no response when infrared sensor be block, please check if the infrared sensors are aligned, Under normal circumstances, the red led of receive sensor is no bright when no blocked .If the red led of receive sensor is always bright ,that means the sensors no shoot well ,please adjust to aligned.

4) The relay time of access control device must be set to 0-1 seconds.

5) When the valid card is swiped, the indicator light turn green, If the indicator indicates incorrect or turn off and alarm immediately when go into first sensor, This means that the signal connection is opposite, exchange the open signal connect terminal of SW1 Gnd to SW2 Gnd

6) Check and test carefully, running smoothly, no abnormal condition, no impact sound, etc; Confirm motor is no idle; the indicator light is correct and the infrared pinch function is normal before putting into use.

2.5 Notice of use

- ❖ If it tests well before installation, then fixed it; before you install and maintain it, please cut off the power;
- ❖ The product must be earthed, and an earth leakage breaker is necessary on the power supply;
- ❖ The depth of buried PVC tube should be greater than 60mm, and the exposed height above the ground should be greater than 50mm. The exit mouth should be bending back to avoid water dipping inside the tube;
- ❖ Don't change the inside wire of the turnstile casually;
- ❖ Please don't open the turnstile when it is under the working status;
- ❖ In installation, please make each door of the lane are in alignment;
- ❖ If you use the turnstile outdoor, it need to add a 100-200mm cement platform for the turnstile to do damp proof, also need to add a canopy to protect the turnstile from sun and rain;
- ❖ Please keep the control button or remote control far away from the children;
- ❖ Please don't use the turnstile under the thunder and lightning condition to get rid of damage to the equipment.

3 Board and parameter instruction

3.1 Board instruction

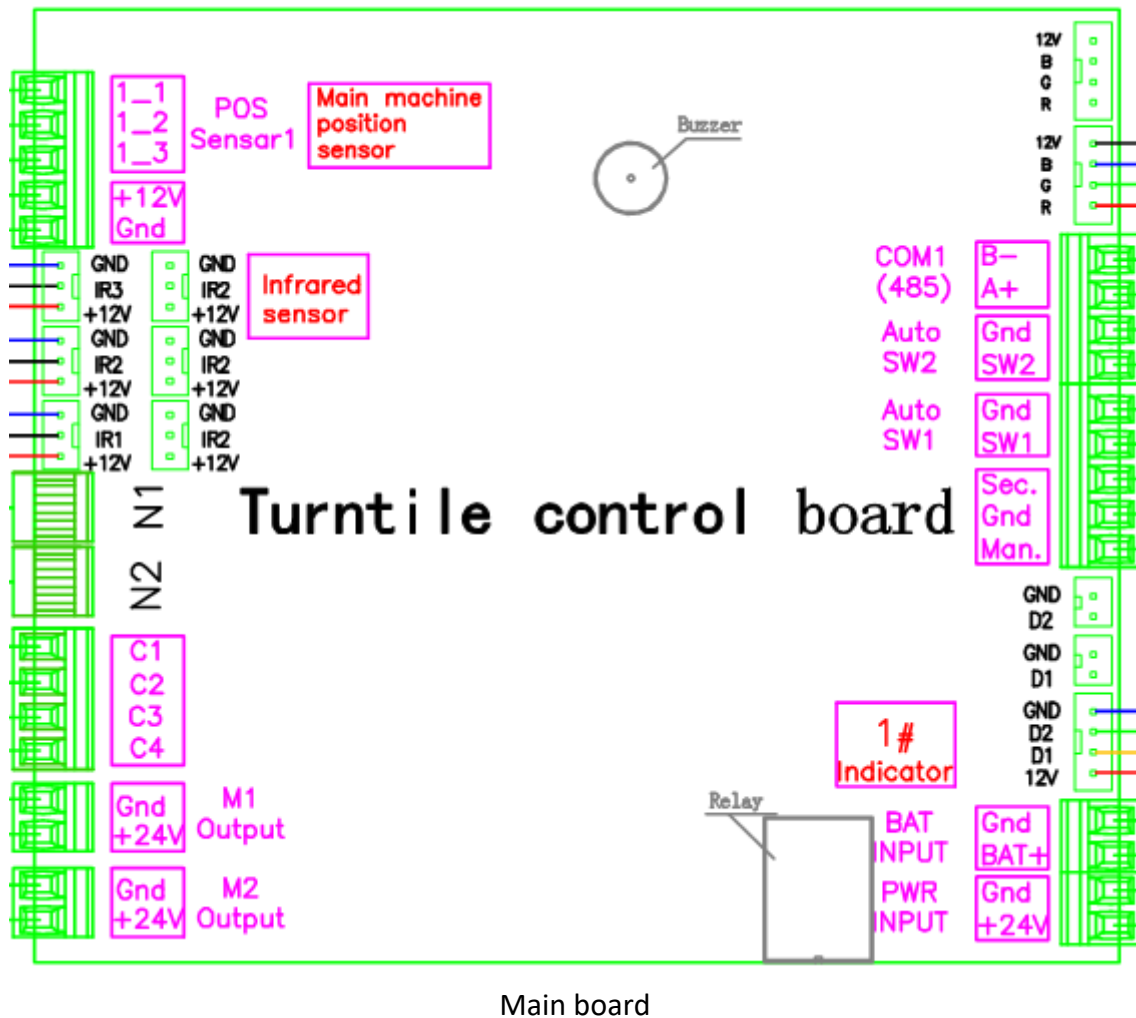

The connect board

Port	Instruction		mark	
(1) PWR INPUT	1	+24V	24VDC power supply	
	2	GND		
(2) BAT INPUT	3	BAT+	12V battery input port	
	4	GND		
(3) Entry Indicator1	5	+12V	Output for indicator of master machine	
	6	GND		
	7	D1		D1 for enter direction
	8	D2	D2 for exit direction	
(4) Man	9	Man	Normally open input	Short for normally open ,

Gnd Sec	10	Gnd	Fire alarm input	Close immediately when cancel
	11	Sec		
(5) Auto SW1	12	SW1	Enter open signal input	Connect to access device NO-SW1 COM-Gnd
	13	Gnd		
(6) Auto SW2	14	SW2	Exit open signal input	Connect to access device NO-SW1 COM-Gnd
	15	Gnd		
(7) COM1 (485)	16	A+	RS485 communication	Protocol docking
	17	B-		
(8) RGB LED	18	R	Negative of LED red	Connect to LED bar
	19	G	Negative of LED green	
	20	B	Negative of LED blue	
	21	+12V	+12V for LED bar	
(9) POS Sensor1	22	1-1	left sensor	Connect to position sensor of core in the master machine, flap /slide gate only use two sensor(open and close)
	23	1-2	Close sensor	
	24	1-3	Right sensor	
	25	+12V	12V output for sensor	
	26	GND		
(10) IR Sensor	27	IR1	Enter infrared sensor	Control board alarm when sensor be block
	28	IR2	Pinch infrared sensor	
	29	IR3	Exit infrared sensor	
	30	+12V	12V output for infrared	
	31	GND		
(11) N1 Entry Indicator 2	32	D2	Output for indicator of master machine D1 for enter direction D2 for exit direction	Connect to indicator of master machine
	33	D1		
	34	GND		
	35	+12V		
POS Sensor2	36	2-1	left sensor	Connect to position sensor of core in the master machine, flap /slide gate only use two sensor(open and close)
	37	2-2	Close sensor	
	38	2-3	Right sensor	
	39	+12V	12V output for sensor	
	40	GND		
(12) N2	41	C1	Reader reserve a place	
	42	C2		
	43	C3		
	44	C4		
	45	R	Negative of LED red	Connect to LED bar
	46	G	Negative of LED green	
	47	B	Negative of LED blue	
	48	+12V	+12V for LED bar	
(13) M1 output	49	GND	Motor output for mater machie	Connect to motor of master machine
	50	+24V		

(14) M2 output	51	GND	Motor output for vice machine	Connect to motor of vice machine
	52	+24V		

3.3 Parameter instruction

Description: the factory has been set up parameters, please do not modify, if you need to modify the parameters, please proceed under technical guidance.

1. Description

1) The display screen is refers to the main control board of 3 LED display from left to right. Four buttons: up and down for switch, ENT for sub-menu, ESC for previous menu. Long press "ENT " 3 seconds unlock into the menu. Select advanced parameters, and long press "ENT + Down " 3 seconds unlock into the menu.



2. Menu setting

Item	Explain
1. Parameters	
1.1 Counter	Display pass through count
1.2 Gate Mode	Set Gate Mode(NO, NC and card, free or reject) of enter and exit 1.NC both Rej 2 .NC both free 3.NC both card (default) 4 NC Card Free 5 .NC Card Rej 6. NC Free card 7.NC Free Rej 8.NC Rej Free 9.NC Rej Card 10.NO Both Free 11.NO Both Card 12.NO Card Free 13.NO Free Card
1.3 PassTimeout	Set maximum waiting time 10-255, unit 0.1s, (default 5seconds)
1.4 Memory	Set Scan Card With Memory Mode 0 two-way disable(default),1. enter allow,2. exit allow,3. two-way allow
1.5 ReadIn Lane	Set Can Scan Card After Entry Lane,Please do not modify 1. disable (default), 2. allow
1.6 Open Delay	Set Authorized Open Door Delay 0-255, unit 0.1s, (default 0)
1.7 CLS. Delay	Set Close Door Delay After Passage Finish0-255, unit0.1s, (default 0)
1.8 Motor1 SPD.	Set master Motor basic speed 1-100
1.9 Motor2 SPD.	Set vice motor basic speed 1-100

1.10 Pass End	Set IR Check passage end position 1. exit (default), 1 safety
1.11 Intrude Set	Set Intrude Alarm Mode 1.no alarm, 2 .alarm (default), 3. alarm and close
1.12 Reverse Set.	Set Passage From Reverse Alarm Mode 1 no alarm, 2. alarm, 3 alarm and close (default),
1.13 Tail-Gating	Set Tail-Gating Alarm Mode 1 no alarm, 2. alarm, 3 alarm and close (default),
1.14 Adv. Param.	
.1 EN_O_SPD.1	Set Motor 1 Speed when Open Door for Entry
.2 EN_C_SPD.1	Set Motor 2 Speed when Open Door for Entry
.3 EX_O_SPD.1	Set Motor 1 Speed when Close Door for Entry
.4 EX_C_SPD.1	Set Motor 2 Speed when Close Door for Entry
.5 EN_O_SPD.2	Set Motor 1 Speed when Open Door for Exit
.6 EN_C_SPD.2	Set Motor 2 Speed when Open Door for Exit
.7 EX_O_SPD.2	Set Motor 1 Speed when Close Door for Exit
.8 EX_C_SPD.2	Set Motor 2 Speed when Close Door for Exit
.9 Save Fact.	Save the current parameter to factory default
.10 Relay Mode	Set add relay use for passed counter 1. disable,(default),2.Enter allow, 3.Exit allow ,4. both ballow
.11 Auto Report	Set automatic report gate status when on change 1 disable (default), 2 allow
.12 NO Direction	Set the normally open the gate opening direction , the default enter
.13 Power Lost	Set the normally open the gate opening direction when Power failure , the default enter
.14 Barriers	signal or double machine work 1 double (default) , 2 signal
.15 IR Speed	Set IR Sensor Sensitivity(1-100) 0-100(default 100)
.15 IR Type	Set infrared sensor type 1 PNP (default), 2 NPN
.16 IR Logic	Set Use Local IR Sensor Logic
.17 Motor Pro.	Set the motor over current protection threshold, the default 2.5A
.18 Self Check	Set use self check when power on, disabled by default
.19 LED Mode	Set LED indicator default parameter 1 Static LED,2 Square LED
.20 Set DevType	Set Controller Device Type 1 Tripod 2 Flap gate, 3 Swing gate
2. System Set	
2.1 Language	Set Menu Display Language
2.2 Device Type	Display Controller Device Type
2.3 Version	Display hardware and firmware version information
2.4 Set Address	Set Device Logic Address

2.5 RS485 Baud	Set the baud rate of the RS485
2.6 Reset	Reset all setting to factory default.
2.7 Restart	Restart controller
3. Factory Test	
3.1 Cycle Test	Open and close door cycle test
3.2 Input Check	Check input interface status
3.3 Output Test	Output interface test

4 Trouble shooting and maintenance

4.1 Trouble shooting

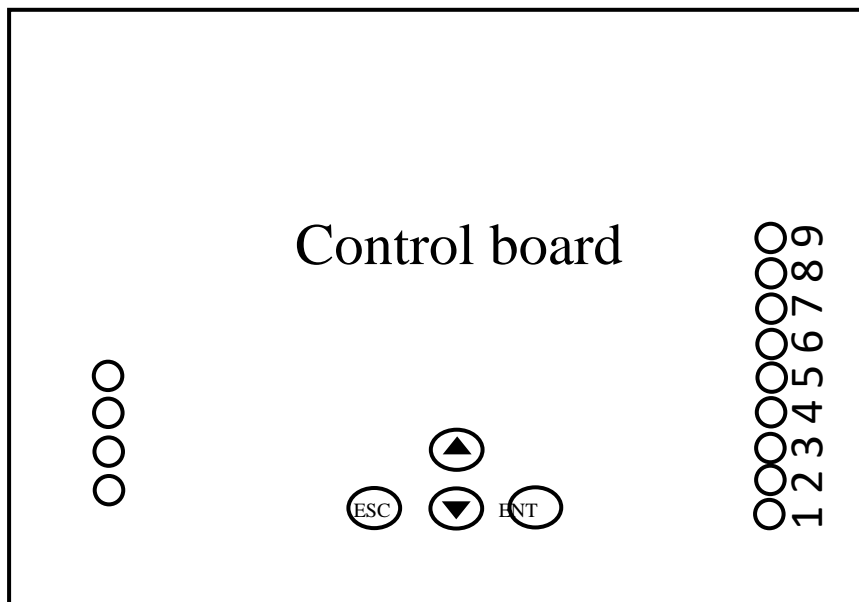

The box of control is buckle type ,It can open the upper cover of the buckle from the side.

Fault 1: Gate automatically open when people in to first sensor?

Answer: Change pass mode two way free to two way card in the menu.

Fault 2: swipe into the first sensor, Gate give alarm and close immediately?

Answer: This means that the signal connection is opposite, exchange the open signal connect terminal of SW1 Gnd to SW2 Gnd.

Fault 3: indicator light is not bright?

Answer: Take the other indicator or control board from other lane and check it

Fault 4: is there an indicator that shows the wrong direction?

Answer: Exchange the connect wire of indicator D1 to D2.

Fault 5: Motor idling?

Answer: 1) Check whether the POS Sensor connect wires are loose; 2) Turn off the power and use the millimeter to check whether the connection between the master machine and the vice machine is continuous. 3) Check the vice board 12VGND for voltage output

Fault 6: there is one side of barrier is not closed?

Answer: 1) Check whether the POS Sensor connect wires are loose; 2) Turn off the power and use the millimeter to check whether the connection between the master machine and the vice machine is continuous. 3) Check the vice board 12VGND for voltage output

Fault 7: swing the side of the pendulum rod can only open 90 degrees, or open the side of the pendulum rod hit the box?

Answer: 1) check the abnormal barrier and the normal one whether there is any difference between the fixed angles and whether the pendulum rod is struck or not 2) Check the iron sheet of core whether is loose, if loose readjust it.

Fault 8: The swing gate move slowly or shake or give big noisy?

Answer: Check core

4.2 Maintenance

Swing /falp barrier gates require regular maintenance by professionals and daily cleaning to ensure long-term stability and extended equipment life.

1. Maintenance Content:

- * Keep the turnstile housing and card reader panels of turnstile gates clean;
- * Fasten and lubricate the internal movement structure;
- * Check the dust of the driver board and make it cleans.
- * Check the connectors and wiring points to ensure the reliability of the connection.

2 Maintenance Methods:

1. Cleaning: Check the housing and card reader panels of the gate, and remove the dust and other dirt to make them clean;

2. Rust removal and Lubrication: Check the movement of the flap /slide gate and swing gate, remove rust with sand paper and spread with anti-rust oil if corroded;
3. Screws fastening: Check the connection of the various moving parts, fasten the screws where they are loose to avoid causing fault for long-running;
4. Circuit board cleaning: Cut off the power, and wipe dust of the board by using a clean brush;
5. Lines Checking: Check the connecting lines and solder reinforcement if they are loose off.

Note: This product is the strong professional technical equipment. In addition to daily maintenance, please do not feel free to disassemble it. If a fault occurs while running, Please notify our service departments or the authorized service agencies promptly to have it maintained. Do not disassemble it at random to avoid damaging the internal structure or even damaging your interests because of your improper operation.



See Far, Go Further