

DS-D4018CW-2FQ 600 × 337.5 Indoor LED



- The display and control system is wholly self-developed, which is stable, safety and controllable.
- Highly integrated and compatible cabinet with simple and lightweight design.
- Easy to disassemble lamp board, power supply, and receiving card on the front side with high- precision aluminum die casting cabinet design.
- The solders are made of lead-free and non-toxic solder paste materials, which will not cause harm to human body and the environment.
- Automatically identify high-brightness and harsh picture details and adjust the brightness of the partial zones with dynamic engine algorithms adopted. The image is soft and comfortable to view and its quality is enhanced when unnecessary power consumption is reduced.
- Automatically remove moisture to protect lamp board from water damage when the device is kept in a humid environment or left unused for a long time.
- Support multiple ways to adjust screen parameters via remote control, tablet, and platforms.
- Special HOB Craft Surface colloid layer for better waterproof, moisture-proof, anti-corrosion, dust-proof, anti-static, anti-oxidation.

▪ Specification

Product Model	
Product Model	DS-D4018CW-2FQ
Product Type	
Product Type	Fine Pixel Pitch Indoor Full-color LED Display
Cabinet	
Pixel Configuration	SMD Triad LED (with glue)
Pixel Pitch Category	P1.8
Pixel Pitch	1.875 mm (0.074")
Pixel Density	284,444 dots/m ²
Modules Component	2 × 2
Dimensions (W × H × D)	600 (W) mm × 337.5 (H) mm × 29.5 (D) mm (23.622" × 13.287" × 1.161")
Resolution	320 × 180
Area	0.2025 m ²
Weight	3.4 kg (7.50 lb)
Cabinet Material	Aluminium die casting
Maintenance Method	Front maintenance for all components
Module	
Dimensions	300 mm × 168.75 mm
Module Resolution	160 × 90
Display	
White Balance Brightness	600 cd/m ²
Color Temperature	3000 K to 10000 K adjustable
Viewing Angle	160° (H)/160° (V)
Contrast Ratio	5000:1
Color Uniformity	≤ ± 0.003Cx, Cy
Brightness Uniformity	≥ 97%
Processing Performance	
Driving Method	Constant current driving
Scanning Amount	45
Frame Frequency	60 Hz
Refresh Rate	3840 Hz
Grey Level	16 bit
Power	
Max. Consumption	≤ 460 W/m ² (600 nits)
Average Consumption	≤ 160 W/m ²
Input Voltage	100 to 240 VAC ± 10%
Working Environment	
Working Temperature	-10 °C to 40 °C (14 °F to 104 °F)
Working Humidity	10% RH to 60% RH (without condensation)
Storage Temperature	-20 °C to 60 °C (-4 °F to 140 °F)
Storage Humidity	10% RH to 85% RH (without condensation)
General	
Package Dimensions (W × H × D)	722 (W) mm × 438 (H) mm × 193 (D) mm (28.425 " × 17.244 " × 7.598 ")

Packing List	Regulatory Compliance and Safety Information × 1 Several connecting screws, light beads, driver IC, iron sheets
G.W.	4.5 kg (9.92 lb) (1 package in 1 box)
Net Weight	3.4 kg (7.50 lb)

▪ Available Model

DS-D4018CW-2FQ



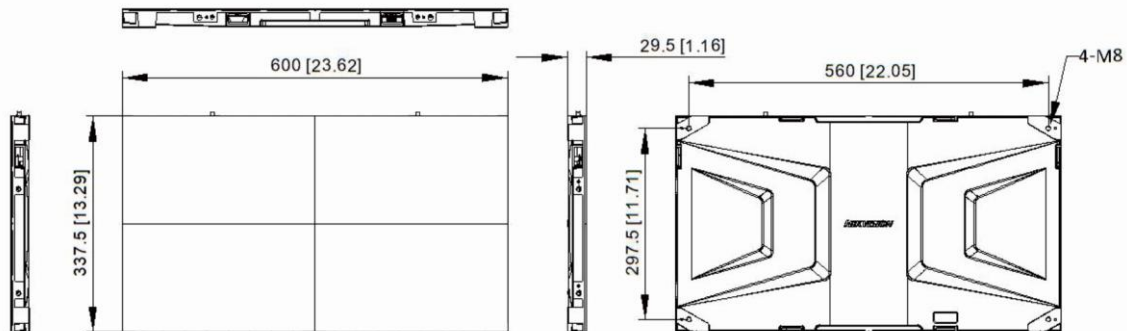

▪ Dimension

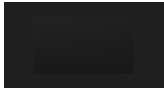

Unit: mm [inch]

▪ Accessory

▪ Optional

DS-1NP6UEC0 CAT6, U/UTP, 24AWG, CU	DS-D4018CW-2F/M (Module)	DS-D40CW-2F/R (Receiving Card)	DS-D40W-2F/H (HUB)	DS-D40W-2F/PC (Power Cable)
				

Headquarters

No.555 Qianmo Road, Binjiang District,
Hangzhou 310051, China
T +86-571-8807-5998
www.hikvision.com



Follow us on social media to get the latest product and solution information.



Hikvision



HikvisionHQ



HikvisionHQ



Hikvision_Global



Hikvision
Corporate Channel



hikvisionhq