



DS-K3G411X Series Tripod Turnstile

Quick Start Guide

UD32866B-A

Quick Start Flow Chart

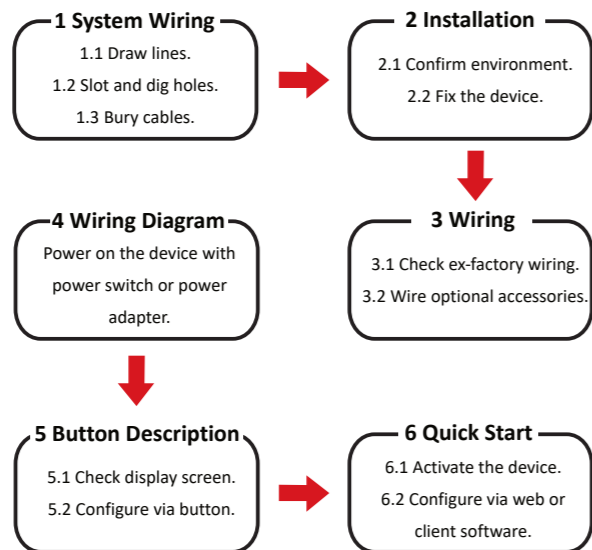

Scan the QR code to view the user manual.



1 System Wiring

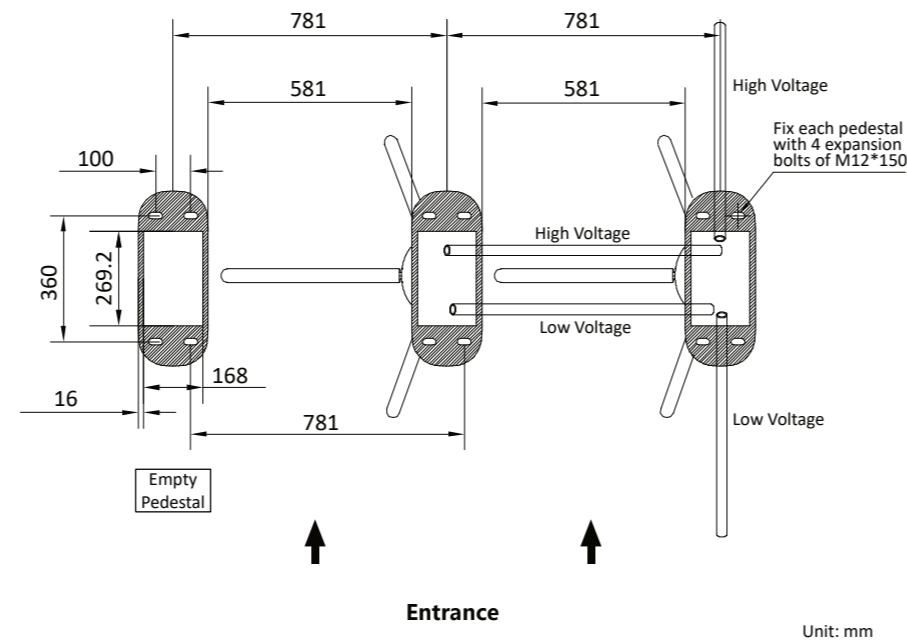

- Steps:**
1. Draw a central line on the installation surface of the left or right pedestal.
 2. Draw other parallel lines for installing the other pedestals.
 3. Slot on the installation surface and dig installation holes according to the hole position. Put 4 expansion bolts of M12*150 for each pedestal.
 4. Bury cables. Each lane buries 1 high voltage cable and 1 low voltage cable. For details, see the system wiring diagram.

- Steps:**
- High voltage: AC power input
 - Low voltage: network cable (CAT5E or CAT6), interconnecting data cable and interconnecting power cable.
 - The supplied interconnecting power cable length is 3.75 m, if necessary, you can contact the sales person to replace it with a 5.5 m cable.
 - The suggested inner diameter of the high and low voltage conduit is larger than 30 mm. If the switch (optional) is selected, the suggested inner diameter of the high voltage conduit is larger than 30 mm.
 - If you want to bury both of the high voltage cable and the interconnecting cable, the two cables should be in separated conduits to avoid interference.
 - If more peripherals are required to connect, you should increase the conduit diameter or bury another conduit for the external cables.

2 Installation

- Steps:**
1. Prepare installation tools, check the components, and clean the installation base.
 2. Dig holes on the ground according to the installation holes on the pedestals and insert the expansion bolts.
 3. Place the pedestals properly on the base.
 4. Seal the bottom of the turnstile to avoid water from entering.
 5. Secure the pedestals with expansion bolts.

- Steps:**
- Make sure the device is installed on flat surface.
 - Make sure the device is powered off during installation and other operations.
 - The installation tools are put inside the package of the pedestal.
 - To prevent stainless steel from rusting due to dirt during construction, it is recommended that the protective film be removed after the installation is completed. There may be residual adhesive at the film cutting position. It is recommended to use WD-40 protective liquid to wipe after tearing the film.
 - Avoid immersing the pedestal in water. Under special circumstances, the immersion height should not exceed 150 mm.

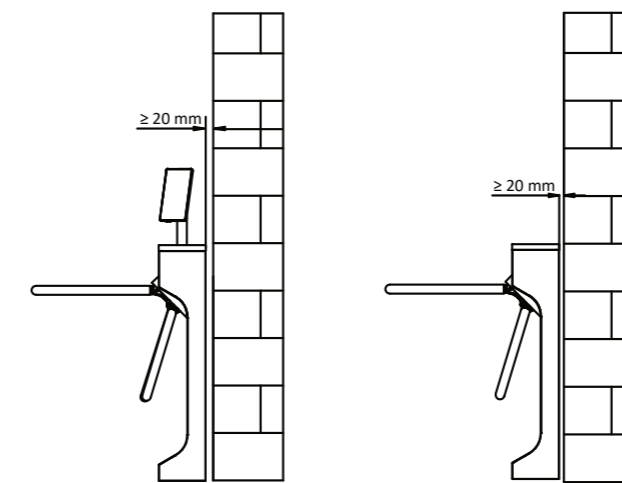

If the installation area is close to the wall, make sure the distance between the pedestal and the wall should be more than 20 mm, or you might cause damage to the device or cannot open the pedestal's top panel.

Dimension

Scan the QR code to view the video guide.

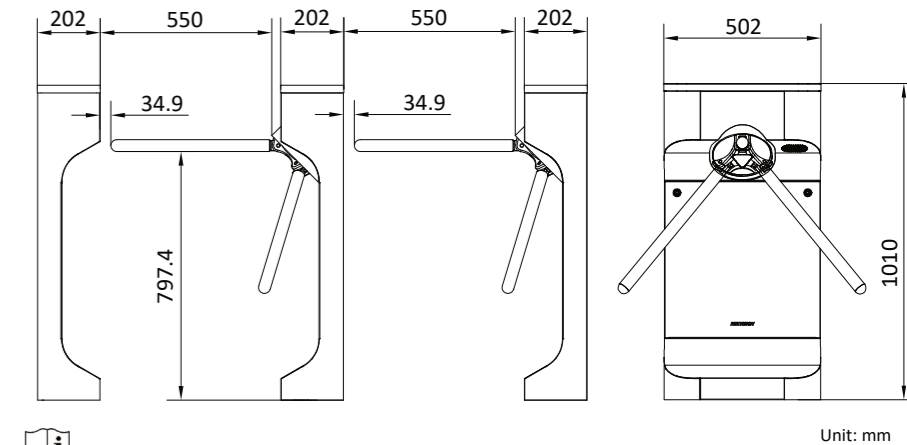

● The diagram is for reference. Dimensions may differ in models.

3 Wiring

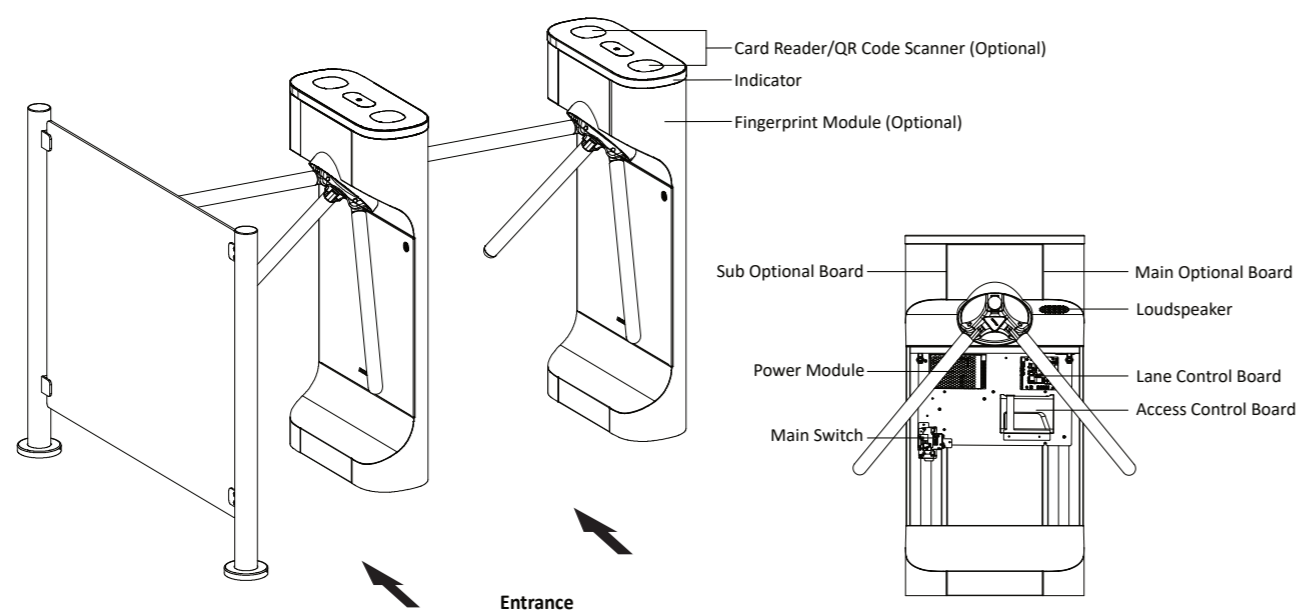

Lane Control Board

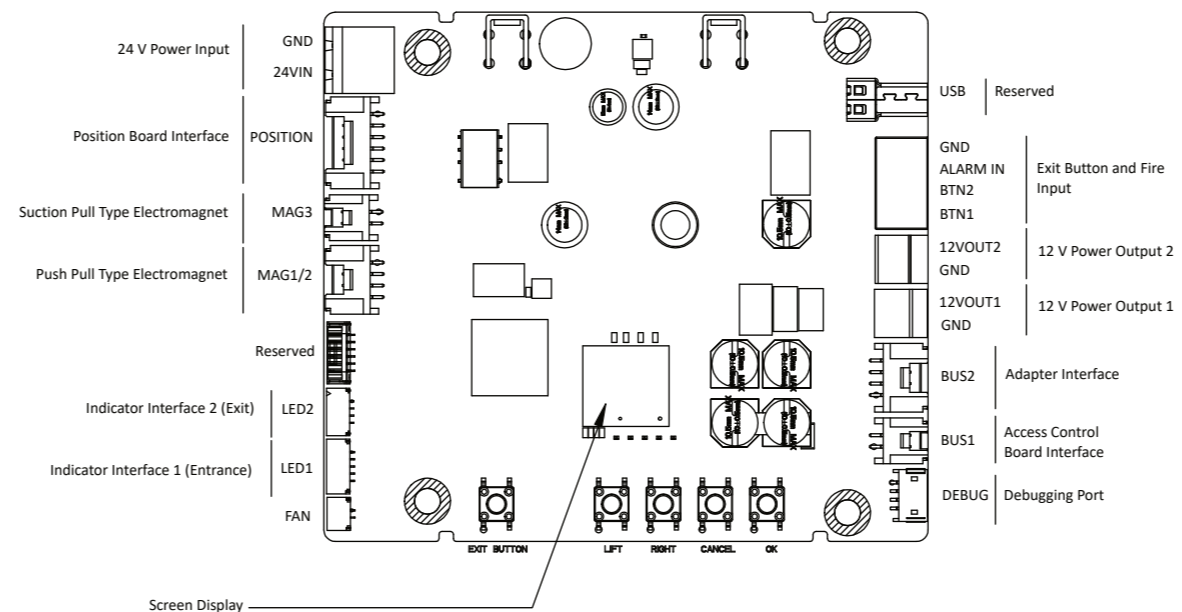

Access Control Board

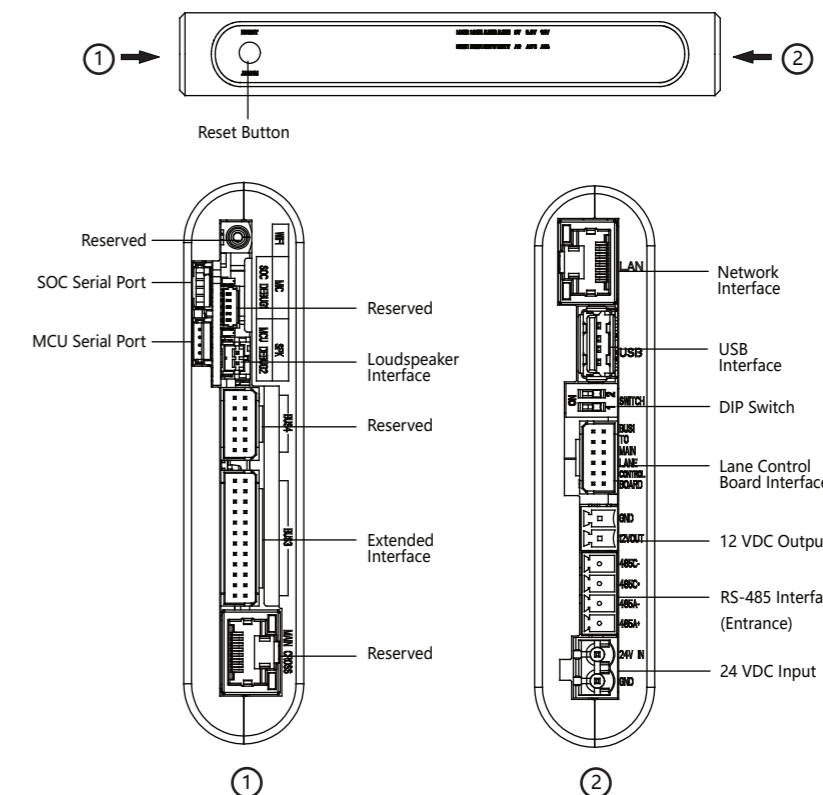

- Steps:**
- SOC and MCU serial port are for debugging and maintenance use only.
 - Hold the reset button for 5 s, the device will beep for 3 s and start restoring to factory settings.
 - RS-485A corresponds to port 5 on web and is for QR code scanner connection at entrance by default; RS-485C corresponds to port 7 on web and is for card reader connection at entrance by default.
 - The DIP switch is for study mode settings and keyfob pairing. Refer to the user manual for details.

©2023 Hangzhou Hikvision Digital Technology Co., Ltd. All rights reserved.
 About this Manual
 The Manual includes instructions for using and managing the Product. Pictures, charts, images and all other information hereinafter are for description and explanation only. The information contained in the Manual is subject to change, without notice, due to firmware updates or other reasons. Please find the latest version of this Manual at the Hikvision website (https://www.hikvision.com/). Please use this Manual with the guidance and assistance of professionals trained in supporting the Product.
 Trademarks
 HIKVISION and other Hikvision's trademarks and logos are the properties of Hikvision in various jurisdictions. Other trademarks and logos mentioned are the properties of their respective owners.
 Disclaimer
 TO THE MAXIMUM EXTENT PERMITTED BY APPLICABLE LAW, THIS MANUAL AND THE PRODUCT DESCRIBED, WITH ITS HARDWARE, SOFTWARE AND FIRMWARE, ARE PROVIDED "AS IS" AND "WITH ALL FAULTS AND ERRORS". HIKVISION MAKES NO WARRANTIES, EXPRESS OR IMPLIED, INCLUDING WITHOUT LIMITATION, MERCHANTABILITY, SATISFACTORY QUALITY, OR FITNESS FOR A PARTICULAR PURPOSE. THE USE OF THE PRODUCT BY YOU IS AT YOUR OWN RISK. IN NO EVENT WILL HIKVISION BE LIABLE TO YOU FOR ANY SPECIAL, CONSEQUENTIAL, INCIDENTAL, OR INDIRECT DAMAGES, INCLUDING, AMONG OTHERS, DAMAGES FOR LOSS OF BUSINESS PROFITS, BUSINESS INTERRUPTION, OR LOSS OF DATA, CORRUPTION OF SYSTEMS, OR LOSS OF DOCUMENTATION, WHETHER BASED ON BREACH OF CONTRACT, TORT (INCLUDING NEGLIGENCE), PRODUCT LIABILITY, OR OTHERWISE, IN CONNECTION WITH THE USE OF THE PRODUCT, EVEN IF HIKVISION HAS BEEN ADVISED OF THE POSSIBILITY OF SUCH DAMAGES OR LOSS.
 YOU ACKNOWLEDGE THAT THE NATURE OF THE INTERNET PROVIDES FOR INHERENT SECURITY RISKS, AND HIKVISION SHALL NOT TAKE ANY RESPONSIBILITIES FOR ABNORMAL OPERATION, PRIVACY LEAKAGE OR OTHER DAMAGES RESULTING FROM CYBER-ATTACK, HACKER ATTACK, VIRUS INFECTION, OR OTHER INTERNET SECURITY RISKS; HOWEVER, HIKVISION WILL PROVIDE TIMELY TECHNICAL SUPPORT IF REQUIRED.
 YOU AGREE TO USE THIS PRODUCT IN COMPLIANCE WITH ALL APPLICABLE LAWS, AND YOU ARE SOLELY RESPONSIBLE FOR ENSURING THAT YOUR USE CONFORMS TO THE APPLICABLE LAW. ESPECIALLY, YOU ARE RESPONSIBLE FOR USING THIS PRODUCT IN A MANNER THAT DOES NOT INFRINGE ON THE RIGHTS OF THIRD PARTIES, INCLUDING WITHOUT LIMITATION, RIGHTS OF PUBLICITY, INTELLECTUAL PROPERTY RIGHTS, OR DATA PROTECTION AND OTHER PRIVACY RIGHTS. YOU SHALL NOT USE THIS PRODUCT FOR ANY PROHIBITED END-USES, INCLUDING THE DEVELOPMENT OR PRODUCTION OF WEAPONS OF MASS DESTRUCTION, THE DEVELOPMENT OR PRODUCTION OF CHEMICAL OR BIOLOGICAL WEAPONS, ANY ACTIVITIES IN THE CONTEXT RELATED TO ANY NUCLEAR EXPLOSIVE OR UNSAFE NUCLEAR FUEL-CYCLE, OR IN SUPPORT OF HUMAN RIGHTS ABUSES.
 IN THE EVENT OF ANY CONFLICTS BETWEEN THIS MANUAL AND THE APPLICABLE LAW, THE LATTER PREVAILS.
 Data Protection
 During the use of device, personal data will be collected, stored and processed. To protect data, the development of Hikvision devices incorporates privacy by design principles. For example, for device with facial recognition features, biometrics data is stored in your device with encryption method; for fingerprint device, only fingerprint template will be saved, which is impossible to reconstruct a fingerprint image. As data controller, you are advised to collect, store, process and transfer data in accordance with the applicable data protection laws and regulations, including without limitation, conducting security controls to safeguard personal data, such as implementing reasonable administrative and physical security controls, conduct periodic reviews and assessments of the effectiveness of your security controls.

Card Reader Board (Optional)

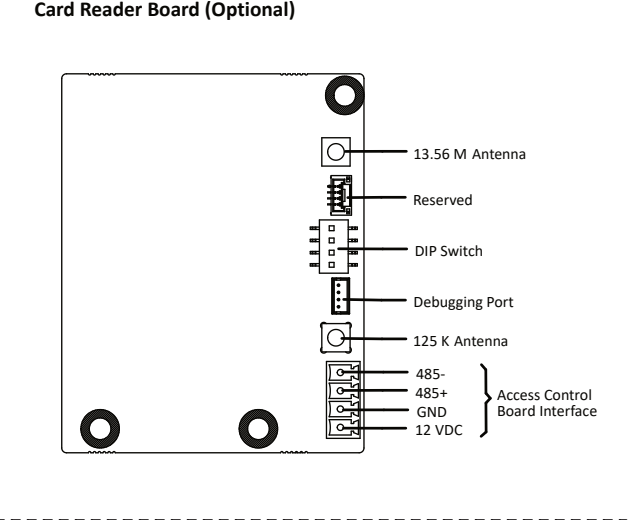

Main Optional Board

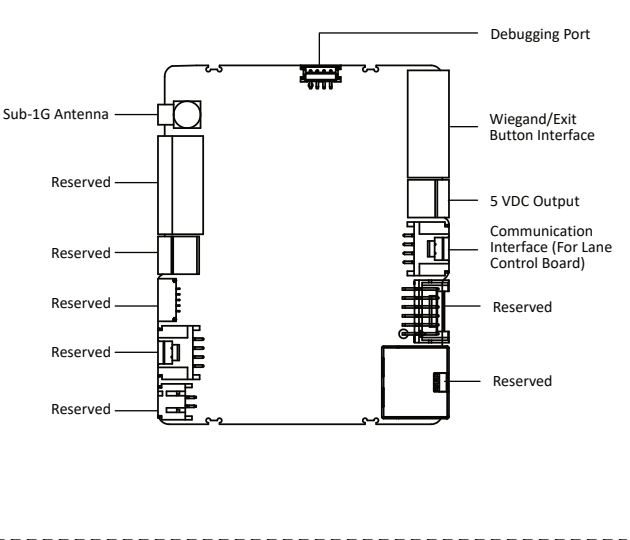

Sub Optional Board

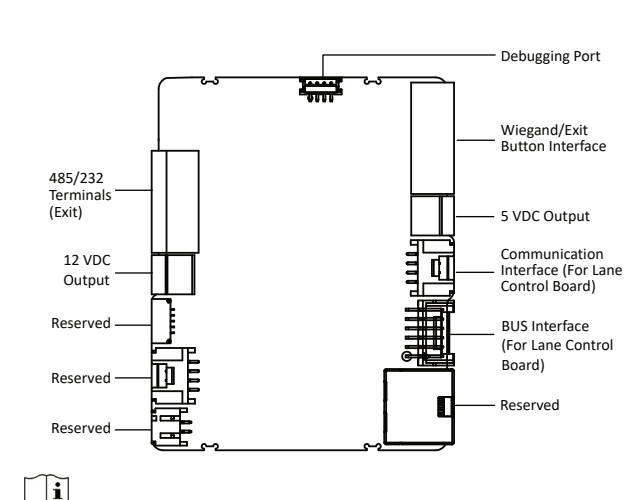

RS-485B corresponds to port 6 on web and is for QR code scanner connection at exit by default; RS-485D corresponds to port 4 on web and is for card reader connection at exit by default; RS-232B corresponds to port 2 on web.

4 Wiring Diagram

- The power cable from power supply to the lane control board has been connected. You will need to prepare the 14 AWG power cable to connect the AC power input to power supply.
- Barrier opens at the entrance/exit: connect to BTN1/BTN2 and GND.
- The power switch can select the input voltage of 220 V or 110 V by the DIP switch, and the default setting is 220 V. Please adjust the DIP switch based on the actual AC voltage to avoid damaging the equipment.
- The two 12 V power output interfaces are the power supply for face recognition modules, which is only supported by the models with power switch.
- For models with power adapter, the power supply for face recognition modules is not contained in package.

Turnstile with Power Switch

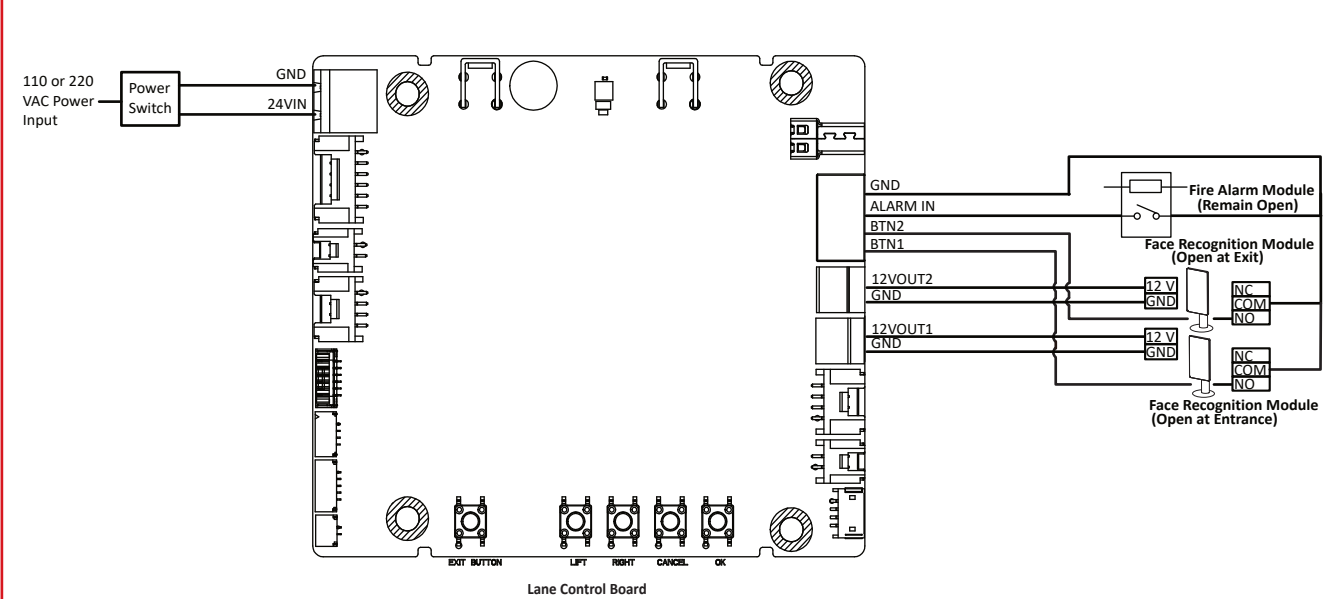

Turnstile with Power Adapter

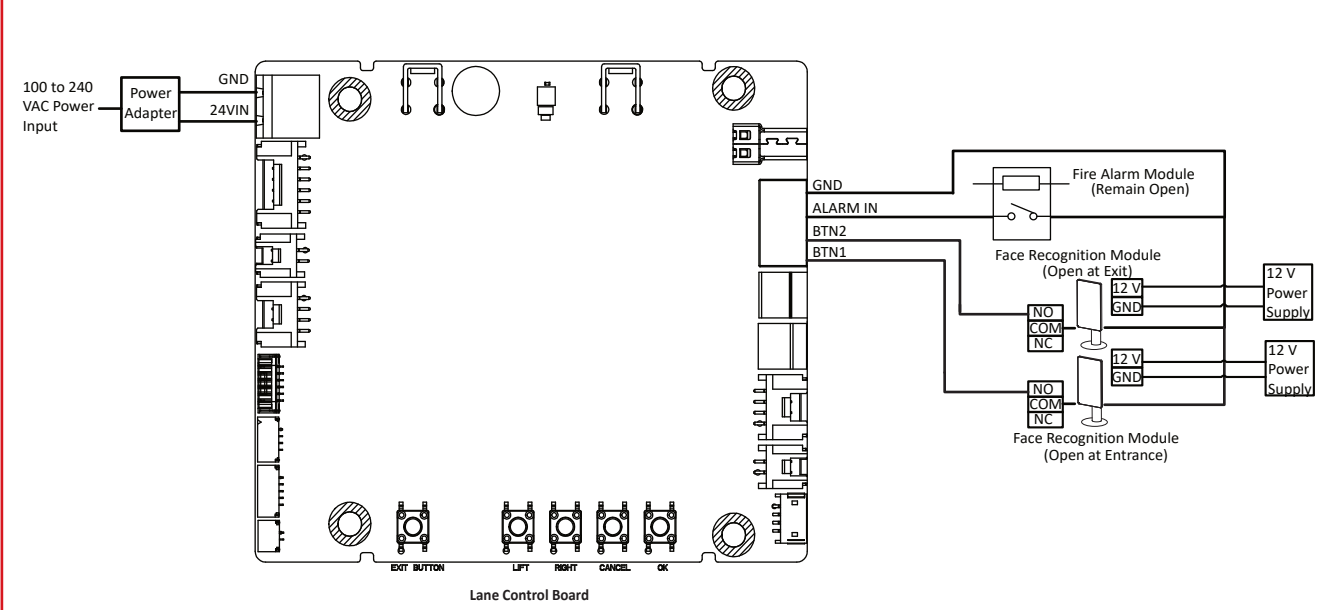

5 Button Description

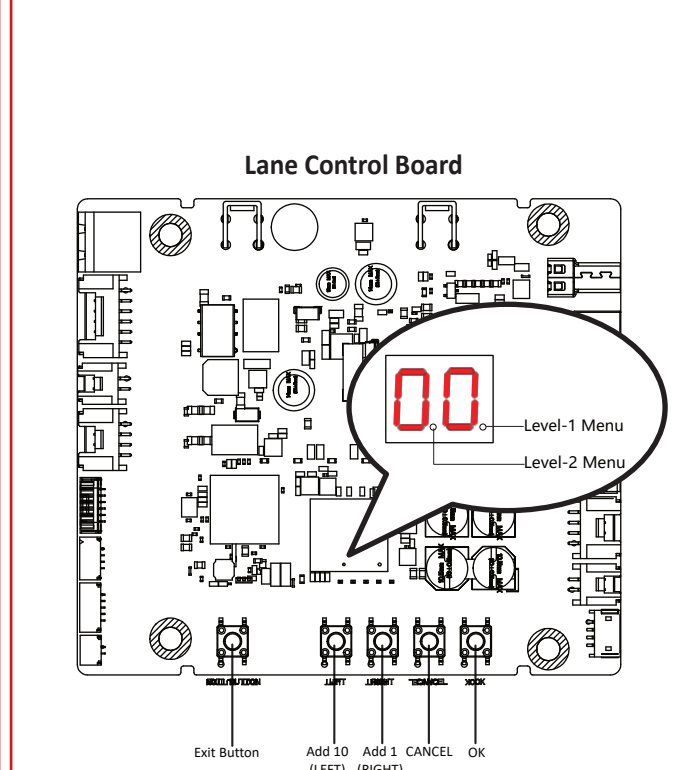

The buttons and the display screen are on the lane control board.

Exit Button
Single press to open from the entrance.
Double press to open from the exit.

Configuration via Button

- Parameter Display
Parameter is displayed by two digital tubes on the screen.
- LEFT
Press the button to add ten to configuration data.
- RIGHT
Press the button to add one configuration data.
- CANCEL
Return to the level-1 menu, or exit the configuration from the level-1 menu.
- OK
Confirm the data, or enter configuration mode, or enter the submenu.
- Level-1 Menu
If the decimal point on the right is on, it indicates the level-1 menu. The number represents the configuration item number.
- Level-2 Menu
If the decimal point in the middle is on, it indicates the level-2 menu. The number represents the parameters of a configuration item.

6 Quick Start

Button Configuration Process

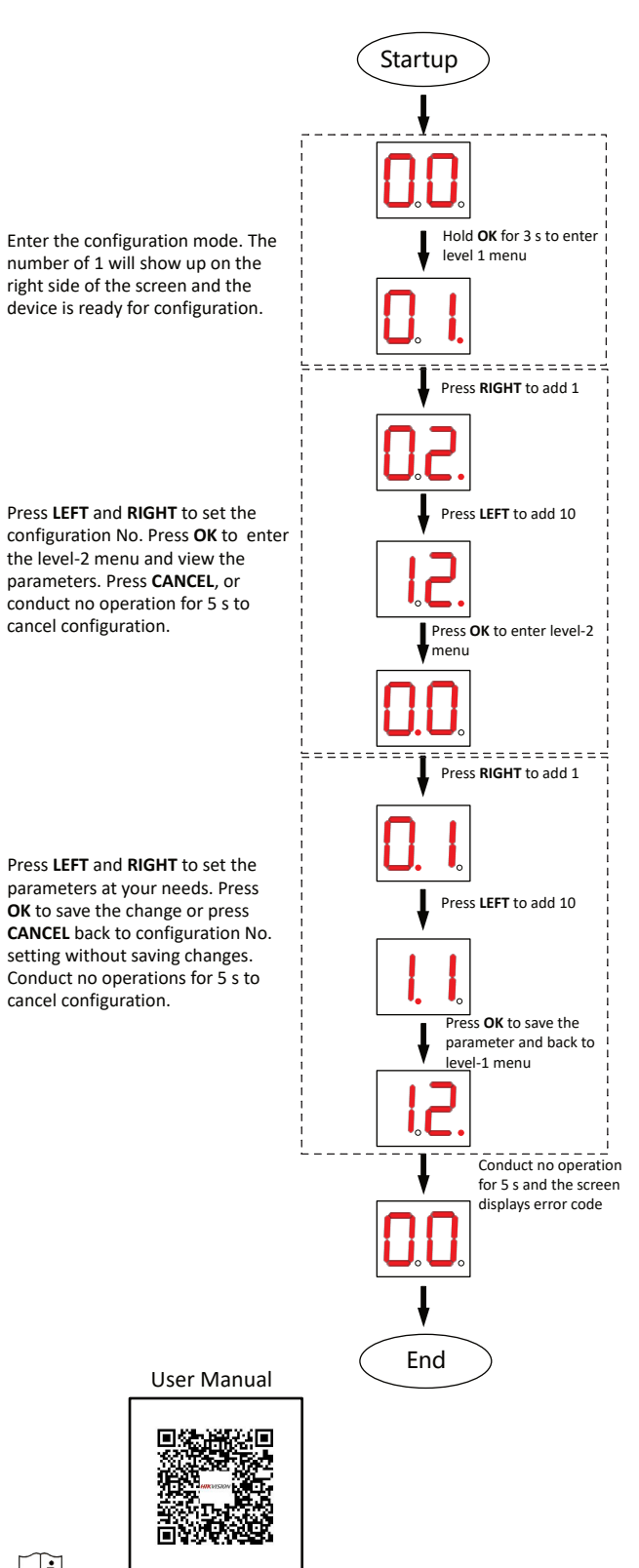

Enter the configuration mode. The number of 1 will show up on the right side of the screen and the device is ready for configuration.

Press LEFT and RIGHT to set the configuration No. Press OK to enter the level-2 menu and view the parameters. Press CANCEL, or conduct no operation for 5 s to cancel configuration.

Press LEFT and RIGHT to set the parameters at your needs. Press OK to save the change or press CANCEL back to configuration No. setting without saving changes. Conduct no operations for 5 s to cancel configuration.



Refer to the user manual for button description details.

6 Quick Start

Activation

- Enter the device default IP address (192.0.0.64) and create a new password (admin password) to activate the device.
 - Activate device via client software.
- We highly recommend you create a strong password of your own choosing (using a minimum of 8 characters, including upper case letters, lower case letters, numbers, and special characters) in order to increase the security of your product. Characters containing admin and nimda are not supported.

Configuration via PC Web

Make sure the device is activated. Enter the device IP address in the address bar of the web browser and press Enter to enter the login page. Enter the device user name and the password. Click Login.

Configuration via Client Software

After downloading the client software, you can conduct device management, group management, person management and access control management.

Safety Instructions

- Warning**
- In the use of the product, you must be in strict compliance with the electrical safety regulations of the nation and region.
 - Do not connect several devices to one power adapter as adapter overload may cause over-heat or fire hazard.
 - If smoke, odors or noise rise from the device, turn off the power at once and unplug the power cable, and then please contact the service center.
 - The equipment must be connected to an earthed mains socket-outlet.
 - Do not touch the bare metal contacts of the inlets after the circuit breaker is turned off. Electricity still exists.
 - 1. This equipment is not suitable for use in locations where children are likely to be present.
 - 2. CAUTION: Risk of explosion if the battery is replaced by an incorrect type.
 - 3. Improper replacement of the battery with an incorrect type may defeat a safeguard (for example, in the case of some lithium battery types).
 - 4. Do not dispose of the battery into fire or a hot oven, or mechanically crush or cut the battery, which may result in an explosion.
 - 5. Do not leave the battery in an extremely high temperature surrounding environment, which may result in an explosion or the leakage of flammable liquid or gas.
 - 6. Do not subject the battery to extremely low air pressure, which may result in an explosion or the leakage of flammable liquid or gas.
 - 7. Dispose of used batteries according to the instructions.
 - Keep body parts away from fan blades. Disconnect the power source during servicing.
 - Keep body parts away from motors. Disconnect the power source during servicing.
 - Never place the equipment in an unstable location. The equipment may fall, causing serious personal injury or death.

Caution

- Do not drop the device or subject it to physical shock, and do not expose it to high electromagnetic radiation. Avoid the equipment installation on vibrations surface or places subject to shock (ignorance can cause equipment damage).
- Do not place the device in extremely hot (refer to the specification of the device for the detailed operating temperature), cold, dusty or damp locations, and do not expose it to high electromagnetic radiation.
- Exposing the equipment to direct sun light, low ventilation or heat source such as heater or radiator is forbidden (ignorance can cause fire danger). The device cover for indoor use shall be kept from rain and moisture.
- Exposing the equipment to direct sun light, low ventilation or heat source such as heater or radiator is forbidden (ignorance can cause fire danger).
- Please use a soft and dry cloth when clean inside and outside surfaces of the device cover, do not use alkaline detergents.
- Biometric recognition products are not completely applicable to anti-spoofing environments. If you require a higher security level, use multiple authentication modes.
- Ensure correct wiring of the terminals for connection to an AC mains supply.
- The equipment has been designed, when required, modified for connection to an IT power distribution system.
- No naked flame sources, such as lighted candles, should be placed on the equipment.
- The USB port of the equipment is used for connecting to a mouse, a keyboard, or a USB flash drive only.
- The serial port of the equipment is used for debugging only.
- This equipment is suitable for mounting on concrete or other non-combustible surface only.
- 1. Install the equipment according to the instructions in this manual.
- 2. To prevent injury, this equipment must be securely attached to the floor/wall in accordance with the installation instructions.
- Keep straight down when moving or using the equipment.

Regulatory Information

CE
This product and - if applicable - the supplied accessories too are marked with "CE" and comply therefore with the applicable harmonized European standards listed under the Directive 2014/30/EU (EMCO), Directive 2014/35/EU (LVD), Directive 2011/65/EU (RoHS).

Battery Symbol
Directive 2006/66/EC and its amendment 2013/56/EU (Battery Directive): This product contains a battery that cannot be disposed of as unsorted municipal waste in the European Union. See the product documentation for specific battery information. The battery is marked with this symbol, which may include lettering to indicate cadmium (Cd), lead (Pb), or mercury (Hg). For proper recycling, return the battery to your supplier or to a designated collection point. For more information see: www.recyclethis.info.

WEEE Symbol
Directive 2012/19/EU (WEEE Directive): Products marked with this symbol cannot be disposed of as unsorted municipal waste in the European Union. For proper recycling, return this product to your local supplier upon the purchase of equivalent new equipment, or dispose of it at designated collection points. For more information see: www.recyclethis.info.