



TEST REPORT

Applicant : Guangzhou Felicity Solar Technology Co., Ltd
Address : No.23 Xingfu Street, Donghua Industrial Zone, Renhe Town, Baiyun District, Guangzhou, 510445 Guangdong, P.R. China
Manufacturer : Guangzhou Felicity Solar Technology Co., Ltd
Address : No.23 Xingfu Street, Donghua Industrial Zone, Renhe Town, Baiyun District, Guangzhou, 510445 Guangdong, P.R. China
Product Name : LiFePO4 Battery System for Households
trademark : 
Model No. : LPBA48200
Ratings : See the copy of marking plate on page 3
Standard : Secondary cells and batteries containing alkaline or other non-acid electrolytes – Safety requirements for secondary lithium cells and batteries, for use in industrial applications
IEC 62619:2022
Date of Receiver : November 02, 2022
Date of Test : November 02, 2022 to November 26, 2022
Date of Issue : November 30, 2022
Test Report Form No : NTCS-IEC 62619-1-A1
Test Result : Pass *

This Test Report is Issued Under the Authority of :

Compiled by

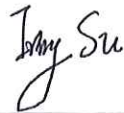

Iring Su / Engineer

Approved by



Han song / Manager

***Remarks:**

The results shown in this test report refer only to the sample(s) tested, this test report cannot be reproduced, except in full, without prior written permission of Shenzhen Nore Testing Center Co., Ltd. The report would be invalid without specific stamp of test institute and the signatures of compiler and approver.

List of Attachments (including a total number of pages in each attachment):
Attachment 1: Photo documentation (6 pages).

Summary of testing:

Tests performed (name of test and test clause):

cl.7.2.3.3 Edge and corner drop test (Battery System)
cl.8.2.2 Overcharge control of voltage (Battery system)
cl.8.2.3 Overcharge control of current (Battery system)
cl.8.2.4 Overheating control (Battery system)

The component cell (FLS-LFP6228082-194Ah) was evaluated according to IEC 62619:2022 by ATS Report No.: ATSL220505561.

The samples comply with the requirement of IEC 62619:2022.

Testing location:

ATS Electronic Technology Co., Ltd.

3/F, Building A, No. 1 Hedong Three Road, Jinxia Community, Changan, Dongguan, Guangdong, China

Summary of compliance with National Differences (List of countries addressed):

No EU Group Differences



The product fulfils the requirements of EN IEC 62619:2022

Copy of marking plate:

The artwork below may be only a draft. The use of certification marks on a product must be authorized by the respective NCBs that own these marks.

The markings below are indicated on the Battery.

This battery has two kinds of labels. The labels are different mainly for the purpose of selling to different customers. Except for the labels, the others are exactly the same.

 <i>Make life full of hope</i> Lithium ion Battery	
Model	LPBA48200
Normal Energy	10KWH
Rated Voltage	51.2V
Normal Capacity	194AH
Recommend Charge&Discharge	80A
Communication	CAN&RS485
Cycle Life	≥6000@25°C,80%DOD
Modules Connection	1~12 in parallel
IFpP/63/281/83/[1P16S]M/-10+50/90	
  	

The disposal instructions are indicated in the battery manual:

- Disposal of batteries should follow local regulations.

Remark:

1. The rule of Date of manufacture was showed as below.

2. Date of manufacture:

YYYY-MM-DD:

YYYY: Year the battery manufactured

MM: Month the battery manufactured

DD: Day the battery manufactured

Appropriate caution statement (Including disposal instructions):

5. EMERGENCY SITUATIONS

Felicity cannot guarantee eStrong battery absolute safety.

5.1 Fire

In case of fires, make sure that the following equipment is available near the system.

- SCBA (self-contained breathing apparatus) and protective gear in compliance with the Directive on Personal Protective Equipment 89/686/EEC.
- NOVEC 1230, FM-200, or dioxide extinguisher

Batteries may explode when heated above 150°C. KEEP FAR AWAY from the battery if it catches fire.

5.2 Leaking Batteries

If the battery pack leaks electrolyte, avoid contact with the leaking liquid or gas. If one is exposed the leaked substance, immediately perform the actions described below.

- Inhalation: Evacuate the contaminated area, and seek medical attention.
- Contact with eyes: Rinse eyes with running water for 5 minutes, and seek medical attention.
- Contact with skin: Wash the affected area thoroughly with soap and water, and seek medical attention.
- Ingestion: Induce vomiting, and seek medical attention.

5.3 Wet Batteries

If the battery pack is wet or submerged in water, do not let people access it, and contact your supplier for help.

Damaged Batteries

Damaged batteries are not fit for use and are dangerous and must be handled with the utmost care. It may leak electrolyte or produce flammable gas. If the battery pack seems to be damaged, pack it in its original container, and then return it to your supplier.

5.4 Warranty

Products that are operated strictly in accordance with the user manual are covered by the warranty. Any violation of this manual may void the warranty.

Limitation of Liability

Any product damage or property loss caused by the following conditions, Felicity does not assume any direct or indirect liability.

- Product modified, design changed or parts replaced.
- Changed, or attempted repairs and erasing of series number or seals;
- System design and installation are not in compliance with standards and regulations;
- The product has been improperly stored in end user's premises;
- Transport damage (including painting scratch caused by movement inside packaging during shipping). A claim should be made directly to shipping or insurance company.

Test item particulars :
Classification of installation and use : To be defined in final product
Supply Connection : Not directly connected to mains :
Possible test case verdicts: - test case does not apply to the test object..... : N/A - test object does meet the requirement..... : P (Pass) - test object does not meet the requirement..... : F (Fail)
Testing :
Date of receipt of test item : 2022-11-02
Date (s) of performance of tests : 2022-11-05 to 2022-11-26
General remarks:
"(See Enclosure #)" refers to additional information appended to the report. "(See appended table)" refers to a table appended to the report.
Throughout this report a <input type="checkbox"/> comma / <input checked="" type="checkbox"/> point is used as the decimal separator.
Name and address of factory (ies) : Guangzhou Felicity Solar Technology Co., Ltd No.23 Xingfu Street, Donghua Industrial Zone, Renhe Town, Baiyun District, Guangzhou, 510445 Guangdong, P.R. China

General product information and other remarks: The LPBA48200 is a rechargeable Lithium Iron Phosphate battery with a nominal voltage of 51.2V and a nominal capacity of 194Ah (LiFePO4 51.2V 194Ah) which is used in energy storage applications. The electric, electronic and software controls and systems for critical safety was subjected to analysis for functional safety according to IEC 60730-1 Annex H. Redundant protections need to communicate with the end device and relies on the end device to achieve The main features of the battery are shown as below:

Item	Component Cell used inside	Battery System
Model Designation	FLS-LFP6228082-194Ah	LPBA48200
Rated capacity (Ah)	194	194
Nominal voltage (V)	3.2	51.2
Maximum Charging Current (A)	194	120
Maximum Discharging Current (A)	194	120
Charge temperature Range (°C)	0 to 60	0 to 55
Discharge temperature Range (°C)	-20 to 65	-20 to 65
Standard Fully Charge Voltage (V)	3.65	57.6
Maximum Charging Voltage (V)	3.7	57.6
End of discharge voltage (V)	2.5	48
Weight	Approx. 3.18kg	Approx. 70.5kg
Designation	IFpP/63/281/83/M/-10+50/90	IFpP/63/281/83/[1P16S]M/-10+50/90
Battery configuration		
Cell in connection	1P16S	
Recommend charging method declared by the manufacturer	Constant current 80A charged to 57.6V, then switch to constant voltage 57.6V charged till charge current decline to 9.7A.	
Recommend discharging method declared by the manufacturer	Discharging the battery with 80A constant current to discharge cut off voltage 48V.	
External dimension (mm)	755mm * 600mm * 160mm (Length x Width x Height)	
Structure (mm):		

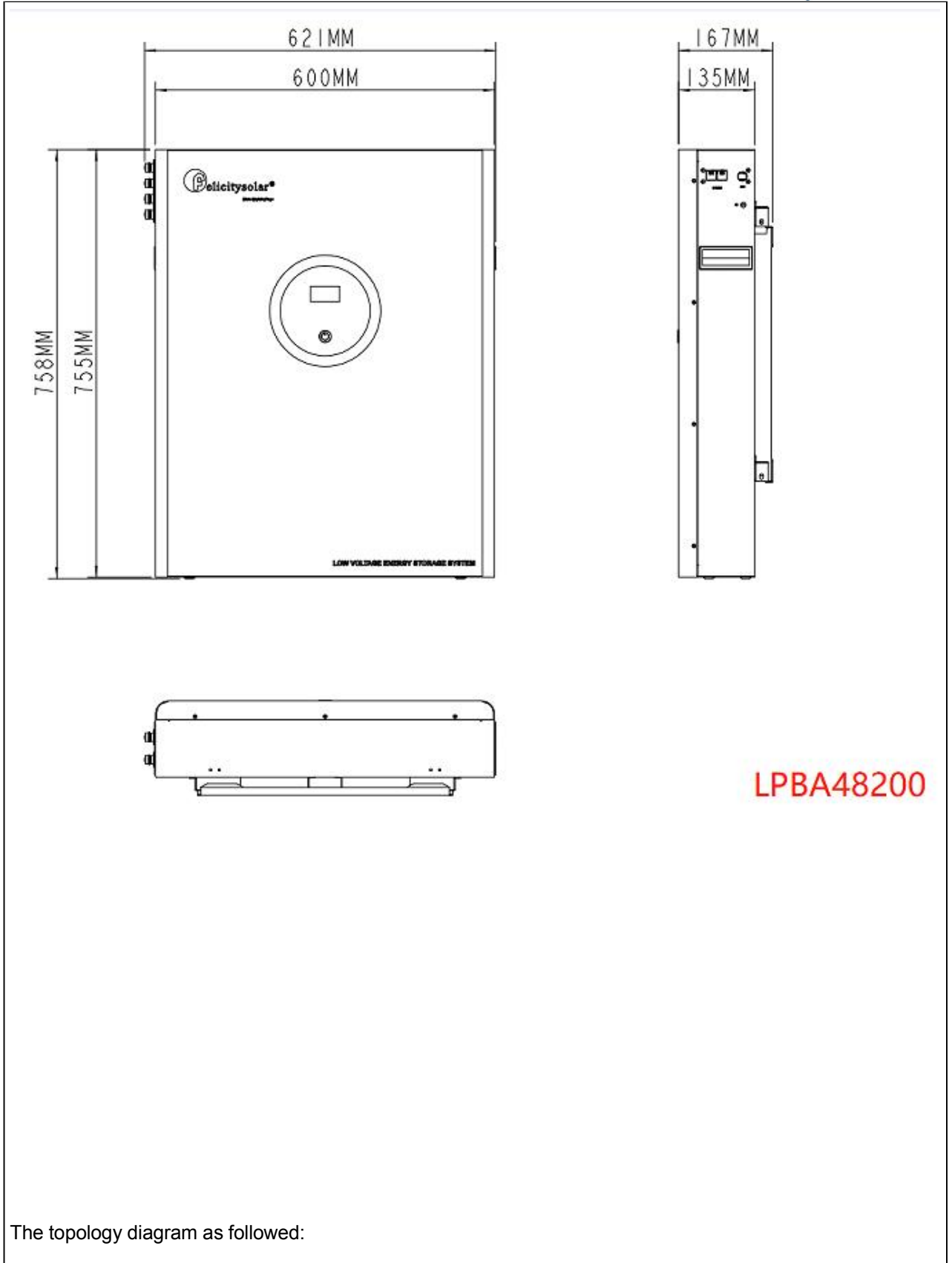

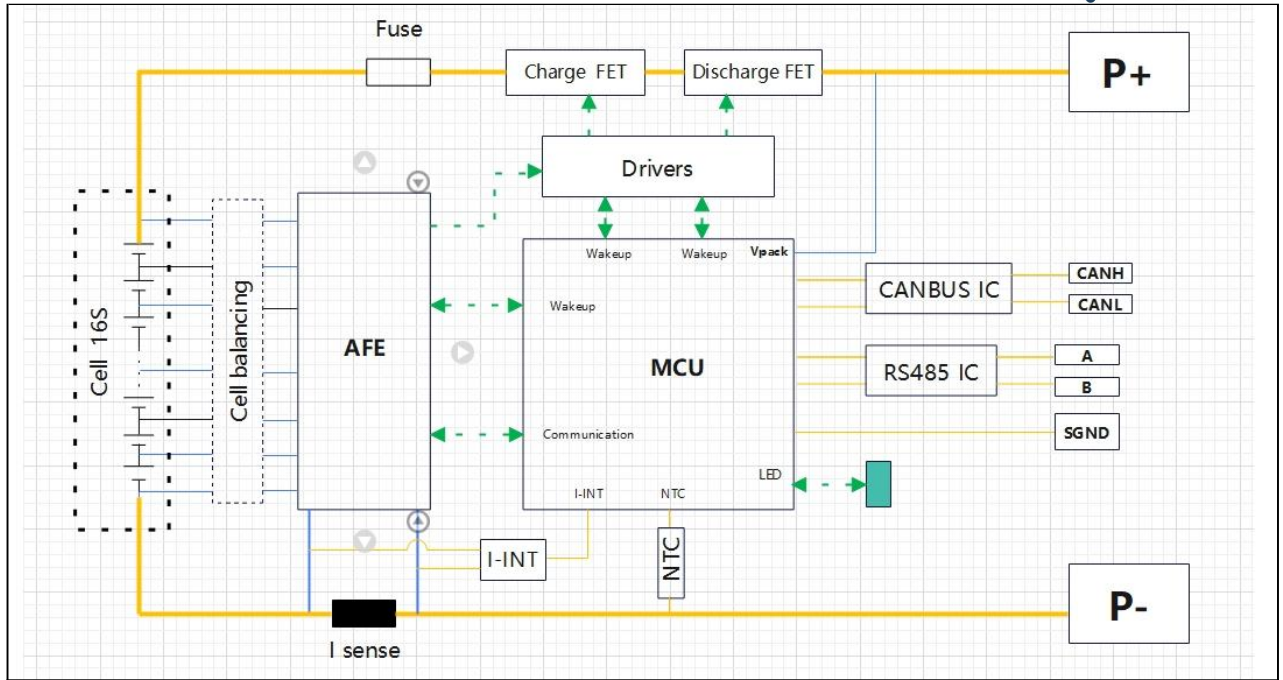

IEC 62619			
Clause	Requirement + Test	Result - Remark	Verdict
4	PARAMETER MEASUREMENT TOLERANCES		P
	Parameter measurement tolerances		P
5	GENERAL SAFETY CONSIDERATIONS		P
5.1	General		P
	Cells and batteries are safe under conditions of both intended use and reasonably foreseeable misuse....:	See also table 5.1 for Critical component information	P
	Reduce the risk of injuries from moving parts		P
5.2	Insulation and wiring		P
	Voltage, current, altitude, and humidity requirements		P
	Adequate clearances and creepage distances between connectors and live parts at different voltages or between live parts and non-current-carrying accessible parts		P
	Protect from hazardous live parts, including during installation		P
	The mechanical integrity of internal connections		P
5.3	Venting		P
	Pressure relief function	Vent design in cell	P
	Encapsulation used to support cells within an outer casing		P
5.4	Temperature/voltage/current management		P
	The design prevents abnormal temperature-rise	Overcharge, over discharge, over current and short-circuit proof circuit used in this battery	P
	Voltage, current, and temperature limits of the cells		P
	Specifications and charging instructions for equipment manufacturers		P
5.5	Terminal contacts of the battery pack and/or battery system		P
	Polarity marking(s)		P
	Polarity marking not provided for keyed external connector		P
	Capability to carry the maximum anticipated current		P
	External terminal contact surfaces		P
	Terminal contacts are arranged to minimize the risk of short circuits		P

IEC 62619			
Clause	Requirement + Test	Result - Remark	Verdict
5.6	Assembly of cells, modules, or battery packs into battery systems		P
5.6.1	General		P
	Independent control and protection method(s)		N/A
	Recommendations of cell operating limits, mounting advice, storage conditions and other design recommendations by the cell manufacturer		P
	Batteries designed for the selective discharge of a portion of their series connected cells	No such design	N/A
	Protective circuit component(s) and consideration to the end-device application		P
5.6.2	Battery system design		P
	The voltage control function		P
	Maximum charging/discharging current of the cell are not exceeded		P
5.7	Operating region of lithium cells and battery systems for safe use		P
	The cell operating region.....:	Listed in the specification of cell	P
	Designation of battery system to comply with the cell operating region	Information mentioned in manufacturer's specification	P
5.8	System lock (or system lock function)		P
	Non-resettable function to stop battery operation	The battery system not deviates from the operating region during operation.	N/A
	Manual with procedure for resetting of battery operation		N/A
	Emergency battery final discharge		N/A
5.9	Quality plan		P
	Manufacturing quality plan (for example: ISO9001, etc.) prepared and implemented.....:	ISO 9001:2015 certification provided	P
	The process capabilities and the process controls		P

6	TYPE TEST CONDITIONS		P
6.1	General		P
6.2	Test items		P
	Cells or batteries that are not more than six months old (See Table 1 of IEC 62619)		P
	Capacity confirmation of the cells or batteries		P

IEC 62619			
Clause	Requirement + Test	Result - Remark	Verdict
	Default ambient temperature of test, 25 °C ± 5 °C	Tests were carried out in an ambient temperature of 25 ± 5°C	P

7	SPECIFIC REQUIREMENTS AND TESTS		P
7.1	Charging procedure for test purposes		P
	The battery discharged to a specified final voltage prior to charging		P
	The cells or batteries charged using the method specified by the manufacturer.....:	The method mentioned in manufacturer's specifications	P
7.2	Reasonably foreseeable misuse		P
7.2.1	External short-circuit test (cell or cell block)	Test report approved cell used.	N/A
	Short circuit with total resistance of 30 m ± 10 m at 25 °C ± 5 °C		N/A
	Results: no fire, no explosion	See Table 7.2.1	N/A
7.2.2	Impact test (cell or cell block)	Test report approved cell used.	N/A
	Cylindrical cell, longitudinal axis impact		N/A
	Prismatic cell, longitudinal axis and lateral axis impact	Prismatic cell	N/A
	Results: no fire, no explosion.		N/A
7.2.3	Drop test (cell or cell block, and battery system)		P
7.2.3.1	General		P
7.2.3.2	Whole drop test (cell or cell block, and battery system)	The mass of battery system is more than 20 kg. Approved Cell Used.	N/A
	Description of the Test Unit.....:	LiFePo4 Prismatic cell	—
	Mass of the test unit (kg).....:		—
	Height of drop (m).....:		—
	Results: no fire, no explosion		N/A
7.2.3.3	Edge and corner drop test (cell or cell block, and battery system)	Tested complied	P
	Description of the Test Unit.....:	Battery system	—
	Mass of the test unit (kg).....:	About 70.5	—
	Height of drop (m).....:	0.1	—
	Results: no fire, no explosion		P
7.2.4	Thermal abuse test (cell or cell block)	Test report approved cell used.	N/A

IEC 62619			
Clause	Requirement + Test	Result - Remark	Verdict
	Results: no fire, no explosion		N/A
7.2.5	Overcharge test (cell or cell block)	Test report approved cell used.	N/A
	For those battery systems that are provided with only a single protection for the charging voltage control		—
	Results: no fire, no explosion.....:		N/A
7.2.6	Forced discharge test (cell or cell block)	Test report approved cell used.	N/A
	Cells connected in series in the battery system..... :		N/A
	Redundant or single protection for discharge voltage control provided in battery system..... :		N/A
	Target Voltage.....:		N/A
	Maximum discharge current of the cell, Im..... :		N/A
	Discharge current for forced discharge, 1.0 It.....:		N/A
	Discharging time, t = (1 It / Im) x 90 (min.).....:		N/A
	Results: no fire, no explosion.....:		N/A
7.3	Considerations for internal short-circuit – Design evaluation		N/A
7.3.1	General	Test report approved cell used.	N/A
7.3.2	Internal short-circuit test (cell)		N/A
	Samples preparation procedure: In accordance with Clause A.5 and A.6 of IEC 62133-2:2017		N/A
	Tested per 7.3.2 b) in an ambient temperature of 25 °C ± 5 °C.		N/A
	The appearance of the short-circuit location recorded by photograph or other means..... :		—
	The pressing was stopped - When a voltage drop of 50 mV was detected; or		N/A
	- The pressing force of 800 N (cylindrical cells) or 400 N (prismatic cells) was reached		N/A
	Results: no fire.....:	7.3.2 for cell have been tested.	N/A
7.3.3	Propagation test (battery system)		N/A
	Method to create a thermal runaway in one cell :		N/A
	Results: No external fire from the battery system, no battery case rupture.....:		N/A

IEC 62619			
Clause	Requirement + Test	Result - Remark	Verdict
8	BATTERY SYSTEM SAFETY (CONSIDERING FUNCTIONAL SAFETY)		P
8.1	General requirements		P
	Functional safety analysis for critical controls	Evaluated according to IEC60730-1 Annex H	P
	Conduct of a process hazard analysis for both the cell manufacturing process and the battery system manufacturing process		P
	Conduct of risk assessment and mitigation of the battery system	FMEA document were provided.	P
8.2	Battery management system (or battery management unit)		P
8.2.1	Requirements for the BMS		P
	The safety integrity level (SIL) target of the BMS		P
	The charge control evaluated by tests in clauses 8.2.2 to 8.2.4		P
8.2.2	Overcharge control of voltage (battery system)		P
	The exceeded charging voltage applied to the whole battery system		P
	The exceeded charging voltage applied to only a part of the battery system, such as the cell(s)..... :		N/A
	Results: no fire, no explosion..... :	See Table 8.2.2.	P
	The BMS terminated the charging before exceeding the upper limit charging voltage		P
8.2.3	Overcharge control of current (battery system)		P
	Results: no fire, no explosion..... :	See Table 8.2.3	P
	The BMS detected the overcharging current and controlled the charging to a level below the maximum charging current		P
8.2.4	Overheating control (battery system)		P
	The cooling system, if provided, was disconnected		N/A
	Elevated temperature for charging, 5 °C above maximum operating temperature..... :		P
	Results: no fire, no explosion..... :	See Table 9.2.5	P
	The BMS detected the overheat temperature and terminated charging		P
	The battery system operated as designed during test		P

IEC 62619			
Clause	Requirement + Test	Result - Remark	Verdict
9	EMC		N/A
	Battery system fulfil EMC requirements of the end-device application.....:	Intended for to be tested in the end use application [include specific application]	N/A

10	INFORMATION FOR SAFETY		P
	The cell manufacturer provides information about current, voltage and temperature limits of their products		P
	The battery system manufacturer provides information regarding how to mitigate hazards to equipment manufacturers or end-users.		P

11	MARKING AND DESIGNATION (REFER TO CLAUSE 5 OF IEC 62620)		P
	The marking items shown in Table 1 in IEC 62620 indicated on the cell, battery system or instruction manual.		P
	Cell or battery system has clear and durable markings		P
	Cell designation		N/A
	Battery designation	IFpP/63/281/83/[1P16S]M/-10+50/90	P
	Battery structure formulation	1P16S	P

12	PACKAGING AND TRANSPORT		N/A
	Refer to Annex D		N/A

ANNEX A	OPERATING REGION OF CELLS FOR SAFE USE		P
A.1	General		P
A.2	Charging conditions for safe use		P
A.3	Consideration on charging voltage		P
A.4	Consideration on temperature		P
A.5	High temperature range	Charging high temperature limit 55°C	P
A.6	Low temperature range	Charging low temperature limit 0°C	P
A.7	Discharging conditions for safe use	-20~65°C	P
A.8	Example of operating region		P

IEC 62619			
Clause	Requirement + Test	Result - Remark	Verdict

ANNEX B	PROCEDURE OF 7.3.3 PROPAGATION TEST BY LASER IRRADIATION		N/A
B.1	General		N/A
B.2	Test conditions		N/A
B.2.1	Cell test (preliminary test)		—
	The cell fully charged according to the manufacturer recommended conditions..... :		—
	Laser irradiation point on the cell..... :		—
	Output power of laser irradiation..... :		—
	Tested in an ambient temperature of 25 °C ± 5 °C		N/A
	Repeat of cell test for 3 times		N/A
B.2.2	Battery system test (main test)		N/A
	The battery system fully charged according to the manufacturer recommended conditions..... :		—
	Target cell to be laser irradiated..... :		—
	The irradiation point on the target cell same or similar as that on the cell test		
	Output power of laser irradiation..... :		—
	Tested in an ambient temperature of 25 °C ± 5 °C		

ANNEX C	PROCEDURE OF 7.3.3 PROPAGATION TEST BY METHODS OTHER THAN LASER		N/A
C.1	General		N/A
C.2	Test conditions:		N/A
	– The battery fully charged according to the manufacturer recommended conditions..... :		—
	– Target cell forced into thermal runaway..... :		—
	– A specially prepared sample (e.g. a heater or a hole for nail penetration provided) used for ease of testing..... :		—
C.3	Method used for initiating the thermal runaway. 1) Heater (Heater, Burner, Laser, Inductive heating) 2) Overcharge 3) Nail penetration of the cell 4) Combination of above methods 5) Other methods..... :		—

IEC 62619			
Clause	Requirement + Test	Result - Remark	Verdict

ANNEX D	PACKAGING AND TRANSPORT		N/A
	The materials and pack design chosen in a way as to prevent the development of unintentional electrical conduction, corrosion of the terminals and ingress of environmental contaminants		N/A
	Regulations concerning international transport of secondary lithium batteries		N/A

IEC 62619			
Clause	Requirement + Test	Result - Remark	Verdict

5.1 TABLE: Critical components information					
Object / part No.	Manufacturer/ trademark	Type / model	Technical data	Standard	Mark(s) of conformity ¹⁾
Cell	ShenZhen Topband BatteryCo., Ltd.	FLS-LFP622808 2-194Ah	3.2V, 194Ah	IEC 62619: 2022	ATS Report No.: ATSL22050 5561
Metal enclosure	DONGGUAN DIYE METAL MANUFACTURING CO.,LTD	Iron Shell	Sheet Metal, min. 1.4mm thick. SIZE:665mm*440mm*185mm	IEC 62619: 2022	Tested with appliance
-Alternative	Interchangeable	Interchangeable	Min. 1.4mm thick.SIZE: 665mm*440mm* 185mm	IEC 62619: 2022	Tested with appliance
Main PCB,	SHEN ZHEN SHICHANG DONG XIN PCB CO LTD	CDX-2	130°C, V-0	UL 94 UL 796	UL E327349
-Alternative	Interchangeable	Interchangeable	V-0, 130°C	UL 94 UL 796	UL approved
CommunicationPCB	SHEN ZHEN SHICHANG DONG XIN PCB CO LTD	CDX-1	130°C, V-0	UL 94 UL 796	UL E327349
-Alternative	Interchangeable	Interchangeable	V-0, 130°C	UL 94 UL 796	UL approved
IC (U1)	Freescale	MC9S08DZ4 8	VDD: -0.3 to 5.8V, Tstg: -55 to -150°C	IEC 62619: 2022	Tested with appliance
MOSFET (Q1 toQ32)	Infineon	IPB042N10N 3G	V _{DS} : 100V, I _D : 137A	IEC 62619: 2022	Tested with appliance
NTC	NANJING SHIHENG ELECTRONIC SCO LTD	MF52A153F3 950	T _{moa} : 100°C	UL 1434	UL E240991
Lead wires	DONGGUAN ZHONGZHEN ENERGY TECHNOLOGY CO.,LTD	3512	4AWG, 200°C, 600Vac	UL758	UL E355578

IEC 62619					
Clause	Requirement + Test			Result - Remark	Verdict
-Alternative	Interchangeable	Interchangeable	7AWG minimum, min. 200°C, min. 600Vac	UL 758	UL approved
DC connector	Shenzhen CityGU Precision Technology Co.,Ltd	P057C016b	80A, Ambient temperature: -40°C ~85°C	EN 61984: 2009	TUV RH certificate No.: R50515 5750001
Supplementary information: ¹⁾ Provided evidence ensures the agreed level of compliance. See OD-CB2039.					

IEC 62619			
Clause	Requirement + Test	Result - Remark	Verdict

7.2.1	TABLE: External short-circuit test (cell or cell block)					N/A
Sample No.	Ambient (at 25°C ± 5°C)	OCV at start of test (V dc)	Resistance of Circuit (mΩ)	Maximum Case Temperature Rise ΔT (°C)	Results	
--	--	--	--	--	--	
--	--	--	--	--	--	

Supplementary information:
A – No fire or Explosion
B – Fire
C – Explosion
D – The test was completed after 6 h
E – The test was completed after the cell casing cooled to 20% of the maximum temperature rise
F – Other (Please explain): ____

7.2.5	TABLE: Overcharge test (cell or cell block)					N/A
Sample No.	OCV at start of test (V dc)	OCV at end of test (V dc)	Measured Maximum Charging Current (A)	Measured Maximum Charging Voltage (V dc)	Max. Cell Case Temperature, (°C)	Results
--	--	--	--	--	--	--
--	--	--	--	--	--	--

Supplementary information:
Results:
A – No fire or Explosion
B – Fire
C – Explosion
D – Test concluded when temperature reached a steady state condition
E – Test concluded when temperature returned to ambient
F – Other (Please explain): ____

7.2.6	TABLE: Forced discharge test (cell or cell block)				N/A
Sample No.	OCV before applying reverse charge, (V dc)	Target Voltage (V dc)	Measured Reverse Charge Current It, (A)	Total Time for Reversed Charge Application (min)	Results
--	--	--	--	--	--

IEC 62619			
Clause	Requirement + Test	Result - Remark	Verdict

Supplementary information:

Results:
A – No fire or Explosion
B – Fire
C – Explosion
D – Other (Please explain): ____

7.3.2	TABLE: Internal short-circuit test (cell)				N/A
Sample No.	OCV at start of test, (V dc)	Particle location ¹⁾	Maximum applied pressure, (N)	Results	
--	--	--	--	--	
--	--	--	--	--	

Supplementary information:

8)..... Identify one of the following:
1: Nickel particle inserted between positive and negative (active material) coated area.
2: Nickel particle inserted between positive aluminium foil and negative active material coated area.

Results:

A – No fire or explosion
B – Fire
C – Explosion
D – Test concluded when 50 mV voltage drop occurred prior to reaching force limit
E – Test concluded when 800/400 N pressure was reached and 50 mV voltage drop was not achieved
F – Test was concluded when fire or explosion occurred
G – Other (Please explain): ____

7.3.3	TABLE: Propagation test (battery system)					N/A
Sample No.	OCV of Battery System Before Test, (V dc)	OCV of Target Cell Before Test, (V dc)	Maximum Cell Case Temperature, (°C)	Maximum DUT Enclosure Temperature, (°C)	Results	
--	--	--	--	--	--	
--	--	--	--	--	--	
Method of cell failure ¹⁾		Location of target cell		Area for fire protection (m²)		
--		--		--		

IEC 62619			
Clause	Requirement + Test	Result - Remark	Verdict

Supplementary information:

- 1) Cell can be failed through laser exposure, applied heat, overcharge, nail penetration or combinations of these failures or other acceptable methods. See supporting documentation for details on cell failure method
- 2) If the battery system has no outer covering, the manufacturer is required to specify the area for fire protection.

Results:
A – No fire external to DUT enclosure or area for fire protection or no battery case rupture
B – Fire external to DUT enclosure or area for fire protection
C – Explosion
D – Battery case rupture
E – Other (Please explain): ____

8.2.2	TABLE: Overcharge control of voltage (battery system)				P
Sample No.	OCV at start of test for Cell/Cell Blocks, (V dc)	Maximum Charging Current, (A)	Max. Charging Voltage, (V dc)	Max. Voltage of Cell/Cell Blocks, (V dc)	Results
SZNTC221110 01SV00-001	3.212~3.221	120	57.921	3.645	A,D,F
--			Charge Voltage Applied Battery System: 1)		
			Whole	Part	
			65.12	N/A	

Supplementary information:

8. The exceeded voltage can be applied to only a part of the system such as the cell(s) in the battery system per Figure 6 of IEC 62619, if it is difficult to do it in using the whole battery system.

Results:
A – No Fire or Explosion
B – Fire
C – Explosion
D – The voltage of the measured cells or cell blocks did not exceed the upper limit charging voltage
E – The voltage of the measured cells or cell blocks did exceed the upper limit charging voltage
F – All function of battery system did operate as intended during the test.
G – All function of battery system did not operate as intended during the test.
H – Other (Please explain): ____

IEC 62619			
Clause	Requirement + Test	Result - Remark	Verdict

8.2.3	TABLE: Overcharge control of current (battery system)			P
Sample No.	OCV at start of test, (V dc)	Max. Charging Current, (A)	Max. Charging Voltage, (V dc)	Results
SZNTC22111001S V00-001	49.580	144	50.123	A,D,F

Supplementary information:

Results:

A – No fire or Explosion

B – Fire

C – Explosion

D – Overcurrent sensing function of BMU did operate and then charging stopped

E – Overcurrent sensing function of BMU did not operate and then charging stopped

F – All function of battery system did operate as intended during the test.

G – All function of battery system did not operate as intended during the test.

H – Other (Please explain): _____

8.2.4	TABLE: Overheating control (battery system)			
Model No.	OCV at start(SOC 50%) of test, V dc	Maximum Charging Current, A	Maximum Charging Voltage, V dc	
SZNTC22111001S V00001	53.06	120	53.98	
Maximum Specified Temperature of Battery System, °C		Maximum Measured Cell Case Temperature, °C		Results
55		54.8		A,D,F

Supplementary information:

Results:

A – No fire or Explosion

B – Fire

C – Explosion

D – Temperature sensing function of BMU did operate and then charging stopped

E – Temperature sensing function of BMU did not operate and then charging stopped

F – All function of battery system did operate as intended during the test.

G – All function of battery system did not operate as intended during the test.

H – Other (Please explain): _____

IEC 62619			
Clause	Requirement + Test	Result - Remark	Verdict

9	TABLE: EMC					N/A
Standard used for EMC test:						
Sample No.	EMC Test Item	Battery Condition	EMC Test Level/ Parameters	Compliance Criteria	Results	
--	--	--	--	--	--	
--	--	--	--	--	--	
--	--	--	--	--	--	

Supplementary information:

Battery Condition During EMC test

1 – In Operation Mode, [] Supplied at _____, [] Load at _____

2 – In non-operation Mode, Battery state of charge (SOC) before test at around _____

Compliance Criteria and Test Results:

A – No fire or Explosion

B – Fire

C – Explosion

D – Battery system did operate as intended during the test.

E - All function of battery system did operate as intended after the test.

F - All function of battery system did not operate as intended during the test, (Please explain): _____

G - Other (Please explain): _____

IEC 62619			
Clause	Requirement + Test	Result - Remark	Verdict

Photo documentation:

Product: LiFePo4 Battery System

Type Designation: LPBA48200

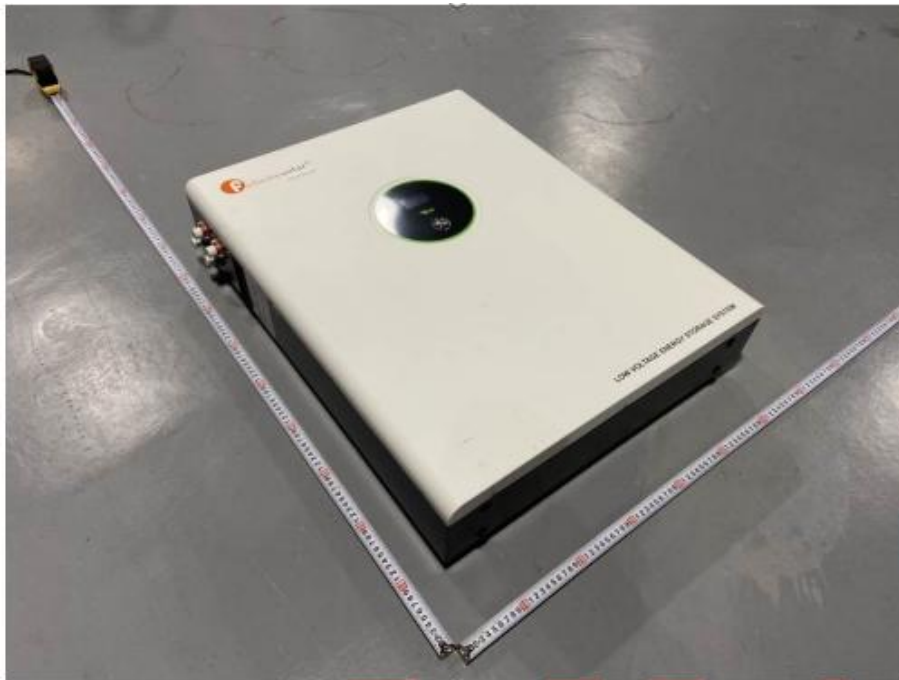

Figure 1 Overall view 1 of battery

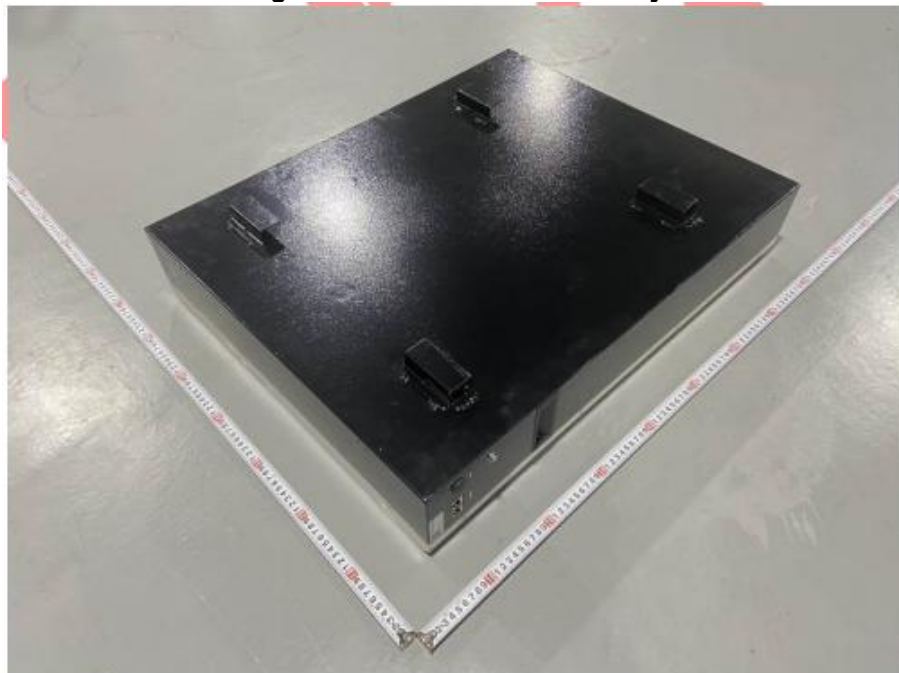

Figure 1 Overall view 2 of battery

IEC 62619			
Clause	Requirement + Test	Result - Remark	Verdict

Product: LiFePo4 Battery System
Type Designation: LPBA48200

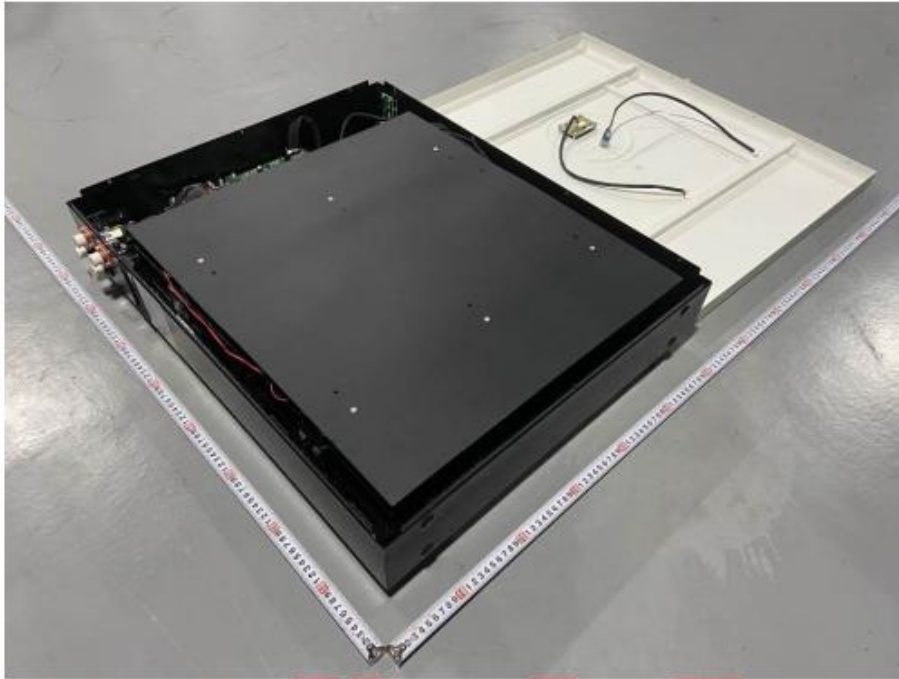

Figure 3 Overall view 1 of battery



Figure 4 Overall view 2 of battery

IEC 62619			
Clause	Requirement + Test	Result - Remark	Verdict

Product: LiFePo4 Battery System
Type Designation: LPBA48200



Figure 5 Overall view of PCB

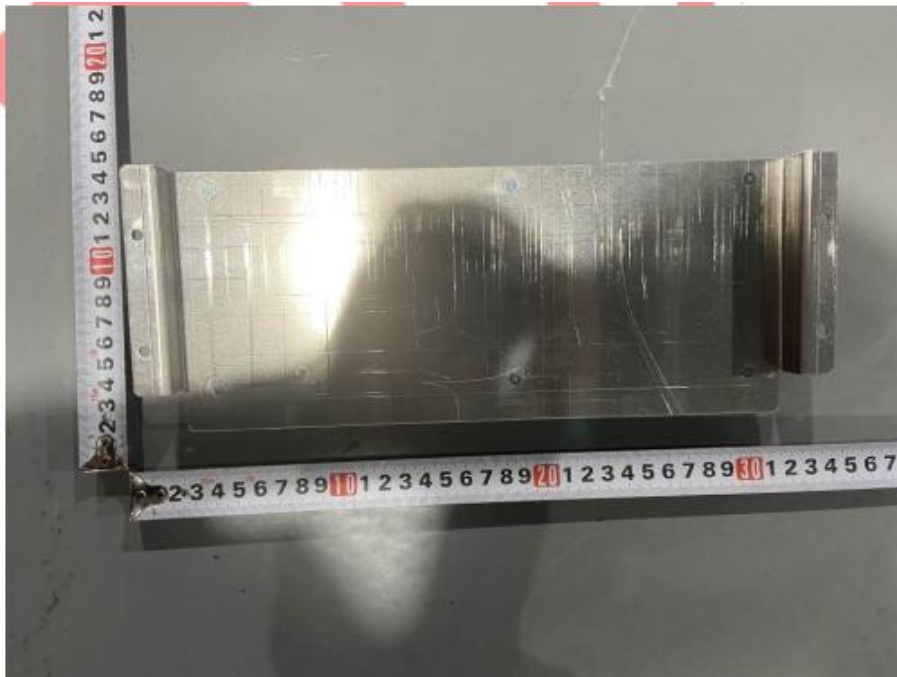

Figure 6 Overall view of PCB

IEC 62619			
Clause	Requirement + Test	Result - Remark	Verdict

Product: LiFePo4 Battery System
Type Designation: LPBA48200



Figure 7 Overall view of PCB



Figure 8 Overall view of PCB

IEC 62619			
Clause	Requirement + Test	Result - Remark	Verdict

Product: LiFePo4 Battery System
Type Designation: LPBA48200



Figure 9 Overall view of PCB



Figure 10 Overall view of PCB

IEC 62619			
Clause	Requirement + Test	Result - Remark	Verdict

Product: LiFePo4 Battery System
Type Designation: LPBA48200



Figure 11 Overall view of PCB

--- END OF TEST REPORT---